

USB Type-C/PD AC-DC Solution

About this diagram

- The green glow added to the Port Controller box indicates it as the Anchor Socket.
- Colored outline of boxes associates that function with the Type-C receptacle marked by the same color.
- Boxes with black outline do not interface with the Type-C receptacle.
- Green text in ALL boxes indicates that ON Semi has a recommended solution for that function.
- The larger box around the Port Controller indicates this as the anchor socket.
- The circuit components are used to provide context of our solution to the ACDC designer.
- Clicking ANYTHING with COLOR will lead to the same next Anchor Socket detail diagram.

[Click for Strata AC-DC Solution](#)

[Click for USB-C/PD - DC-DC Solution](#)

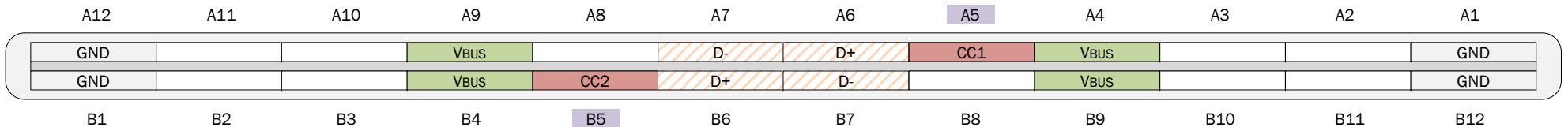
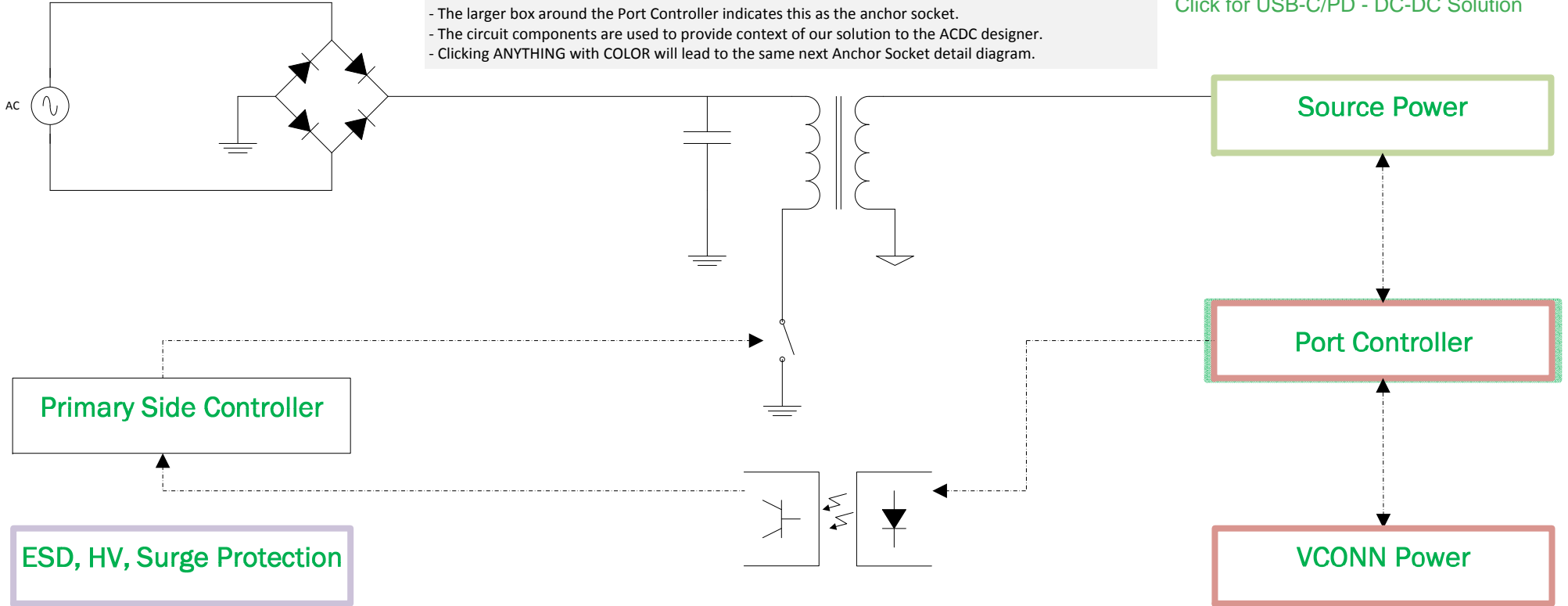

Type-C USB 2.0 Receptacle

contact present, not used | contact not present

About this diagram

- The green fill & part number detail of the Port Controller box indicates it as the Anchor Socket.
- The boxes grouped by color outline associates that function with the Type-C receptacle marked by the same color.
- Clicking any box with a green outline will lead to ON Semiconductor datasheet recommendations for that function.
- Boxes with black outline do not lead to an ON Semiconductor recommended data sheet.
- The circuit components are used to provide context of our solution to the ACDC designer.

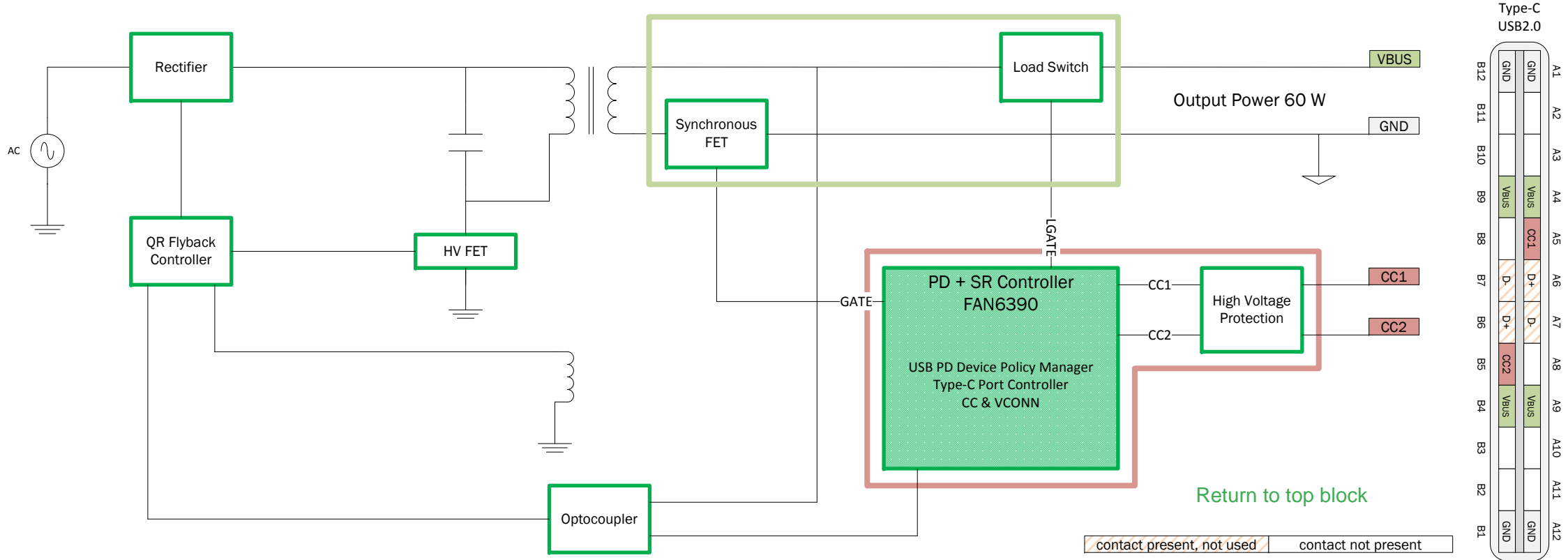

[Return to top block](#)