

# BCR431U low voltage drop linear LED driver IC application note

## Operation, design guide and performance

### About this document

#### Scope and purpose

The BCR431U is an adjustable Constant-Current Regulator (CCR) IC in a small PG-SOT23-6 package. With an internal transistor and minimal external components, it is designed to be easy to use and cost-efficient.

Furthermore, the new BCR43X series with low voltage drop enables increased efficiency and maximal length of LED tape compared with existing BCR products, which helps reduce cost and effort during installation. This document explains the advantages of low voltage drop linear LED driver ICs. It answers common questions regarding the use of BCR431U in LED strip applications.

#### Intended audience

This document is intended for design engineers, application engineers and students, for example, who need to design low-cost, highly reliable linear LED drivers for:

- LED strips
- LED displays and channel letters
- Architectural and landscape lighting
- Retail lighting

### Table of contents

|   |           |
|---|-----------|
| <b>BCR431U low voltage drop linear LED driver IC application note .....</b> | <b>1</b>  |
| <b>About this document.....</b>   | <b>1</b>  |
| <b>1 BCR431U overview and system design considerations.....</b>             | <b>2</b>  |
| 1.1 BCR431U features.....   | 2         |
| <b>2 BCR431U application .....</b>  | <b>4</b>  |
| 2.1 LED current setting.....  | 4         |
| 2.2 Maximum number of LEDs in one string.....                               | 4         |
| 2.3 Thermal protection and power dissipation .....                          | 6         |
| <b>3 Advanced BCR431U design topics.....</b>                                | <b>8</b>  |
| 3.1 Maximum strip length .....  | 8         |
| 3.2 Reverse polarity protection .....                                       | 8         |
| 3.3 Dimming .....   | 9         |
| 3.4 System ESD.....   | 11        |
| <b>4 Appendix: maximum strip-length calculation .....</b>                   | <b>12</b> |
| <b>5 Revision history .....</b>   | <b>14</b> |

# 1 BCR431U overview and system design considerations

## 1.1 BCR431U features

- Supply voltage from 6 V to 42 V
- Controls up to 36.5 mA LED current
- Max. 200 mV saturation voltage  $V_{LED,sat}$  at 36.5 mA
- LED current precision  $\pm 10$  percent
- Smart over-temperature protection function

The application circuit of the device is shown in **Figure 1**. The controller provides a constant current to the LED string, which is determined by the value of  $R_{SET}$ . Capacitor C suppresses high-frequency oscillations in the case of long connecting wires. Although this capacitor is typically only necessary when the wire between the BCR431 and the LED is more than a few centimeters, it is recommended to always place a 10 nF capacitor for improved noise immunity.

The most noteworthy feature of the device is the low voltage drop  $V_{LED,sat}$ , which enables driving more LEDs in a string and longer LED strips with a given supply voltage. Details of how to determine the maximum number of LEDs in a string as well as the maximum strip length are given in the section Maximum number of LEDs in one string.

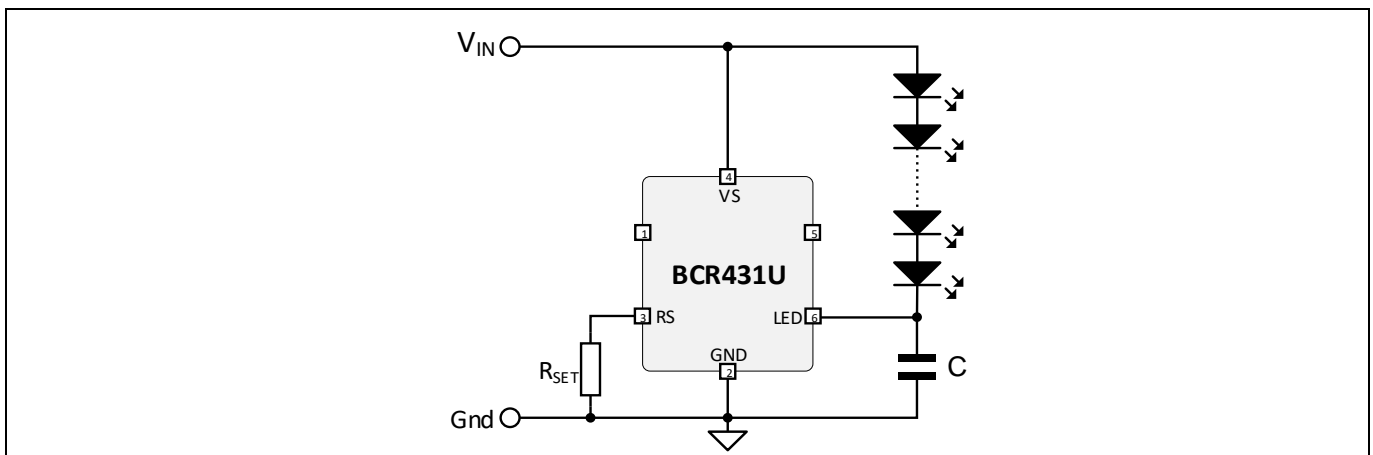

**Figure 1** Application circuit

# BCR431U low voltage drop linear LED driver IC application note



## Operation, design guide and performance

### BCR431U overview and system design considerations

Although the basic application circuit has a simple structure, the designer must consider the boundary conditions of the system this basic circuit may be used in.

- The AC-DC converter providing the input voltage to the BCR431U typically has an accuracy of  $\pm 3$  percent to  $\pm 5$  percent.
- For lighting applications the AC-DC converter needs to comply with the IEC 61000-3-2 standard for line harmonics. Because of that, there is a high likelihood that the output contains a notable amount of AC ripple with double the line frequency. This may reduce the minimum output voltage even further.
- In case the driver is dimmable, this is typically done by Pulse-Width Modulation (PWM) of the power supply output voltage.

How to deal with the above-mentioned boundary conditions is also covered in section 3.

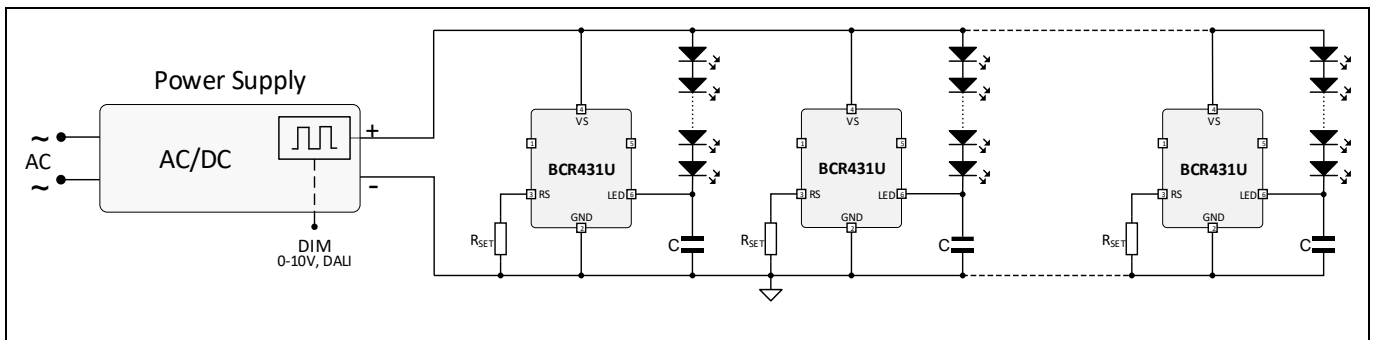

**Figure 2 System block diagram**

## 2 BCR431U application

### 2.1 LED current setting

The LED current is 760 times the current flowing through  $R_{SET}$ . Given the fact that the voltage at the RS pin has a constant value of  $V_{RS} = 1.197\text{ V}$ ,  $I_{LED}$  is finally determined by the equation:

$$I_{LED} = \frac{760 \cdot 1.197\text{V}}{R_{SET}}, \text{ or as pure number equation } I_{LED} \cong \frac{909}{R_{SET}}$$

If the value of  $R_{SET}$  is given in  $k\Omega$ ,  $I_{LED}$  will be in mA.

Instead of connecting it to ground,  $R_{SET}$  can optionally be connected to another voltage  $V_{DIM}$ , smaller than  $V_{RS}$ , in order to reduce  $I_{LED}$ . Then  $I_{LED}$  is given by:

$$I_{LED} = \frac{760 \cdot (1.197\text{V} - V_{DIM})}{R_{SET}}$$

When  $V_{RS}$  is pulled higher than 1.22 V the IC turns off and the output current drops to  $I_{VLED,leak}$ . This can be used to PWM control the LED current. When internal over-temperature protection is activated, the voltage at the RS pin is reduced and output current drops accordingly.

Typical LED current versus  $R_{SET}$  is shown in  $I_{LED}$  vs.  $R_{SET}$ .

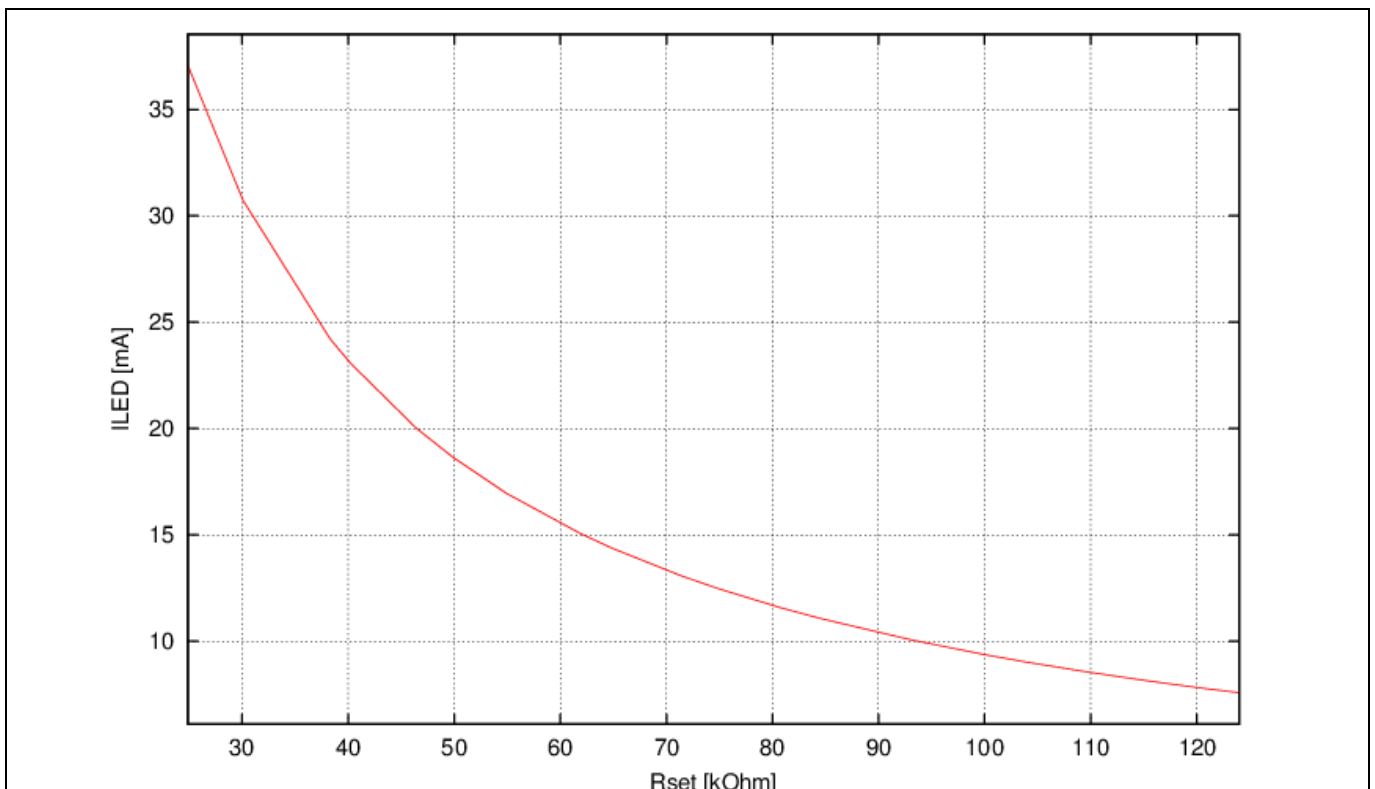
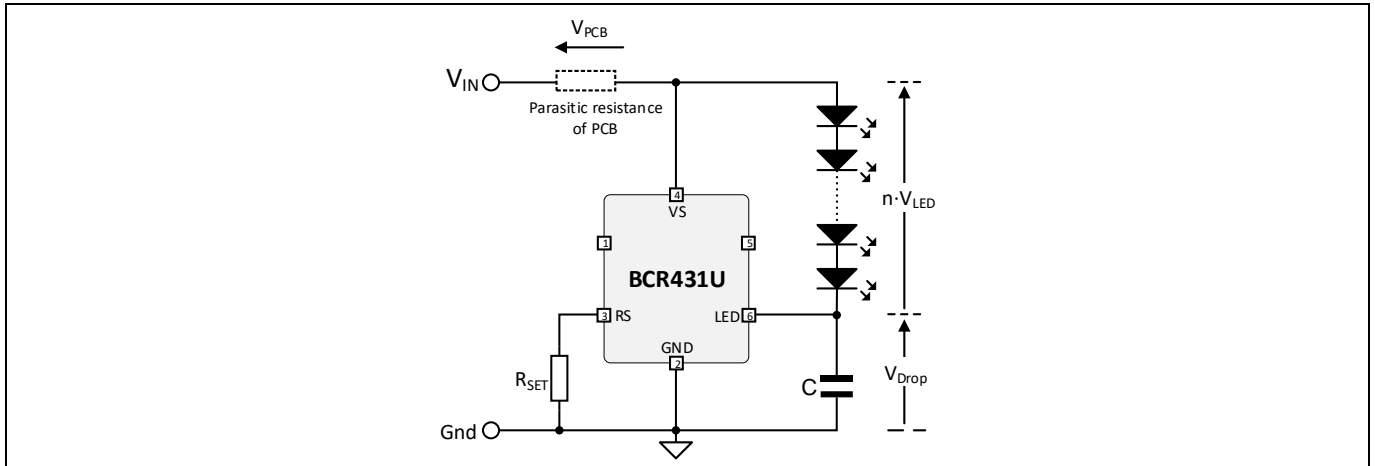

Figure 3  $I_{LED}$  vs.  $R_{SET}$

### 2.2 Maximum number of LEDs in one string

In order to provide a stable LED current, the voltage  $V_{Drop}$  at the LED pin needs to be at least the minimum drop voltage  $V_{LED,sat}$ .



**Figure 4 Definition of voltages**

Its value is given by the equation:

$$V_{LED,sat} \leq V_{Drop,min} = V_{IN,min} - n \cdot V_{LED,max} - V_{PCB}$$

In this equation  $V_{IN,min}$  is the minimum supply voltage, considering the tolerance of the AC-DC converter as well as the output ripple amplitude.  $V_{LED,max}$  is the maximum voltage drop of one LED, occurring at the minimum ambient temperature of the application, and  $n$  is the number of LEDs in a string. Finally,  $V_{PCB}$  is the voltage drop due to PCB trace resistance.

Although  $V_{Drop,min}$  needs to be higher than  $V_{LED,sat}$ , it should be kept as small as possible in order to limit power dissipation of BCR431U.

The above equation can be rearranged to provide the maximum possible number of LEDs in a string:

$$n \leq \frac{V_{IN,min} - V_{PCB} - V_{LED,sat}}{V_{LED,max}}$$

It is obvious that for given  $V_{IN,min}$ ,  $V_{PCB}$  and  $V_{LED,max}$  the number of LEDs in a string increases with lower  $V_{LED,sat}$ .

#### Examples:

- Assume the following design parameters:

$$\begin{aligned} V_{IN,min} &= 23 \text{ V} \\ V_{LED,max} &= 3.2 \text{ V} \\ V_{PCB} &= 0 \text{ V} \\ V_{LED,sat} &= 1.5 \text{ V} \end{aligned}$$

$$n \leq \frac{23 \text{ V} - 1.5 \text{ V}}{3.2 \text{ V}} = 6.72$$

Consequently, the maximum number of LEDs in a string will be six under these conditions.

- With all parameters identical to those above, but  $V_{LED,sat} = 0.2 \text{ V}$

$$n \leq \frac{23 \text{ V} - 0.2 \text{ V}}{3.2 \text{ V}} = 7.12$$

With the lower  $V_{Drop}$ , seven LEDs can be in a string and there is still some headroom for additional copper losses.

3. Again, parameters as listed in 1. but  $V_{LED,max} = 2.8\text{ V}$

$$n \leq \frac{23\text{ V} - 1.5\text{ V}}{2.8\text{ V}} = 7.68$$

It's not surprising that more LEDs, seven in this case, can be operated at a given voltage if forward voltage of LEDs is lower.

4. The same parameters as listed in 1, but  $V_{LED,max} = 2.8\text{ V}$  and  $V_{Drop} = 0.2\text{ V}$

$$n \leq \frac{23\text{ V} - 0.2\text{ V}}{2.8\text{ V}} = 8.14$$

Due to low drop and low forward voltage eight LEDs in one string are possible.

### 2.3 Thermal protection and power dissipation

The BCR43x family employs an advanced thermal protection feature. Up to a junction temperature  $T_J$  of  $100^\circ\text{C}$  the regulated current keeps its set value, while it is gradually reduced above that temperature. At  $T_J = 120^\circ\text{C}$  the current is reduced to 80 percent of set value, finally reaching about 30 percent of nominal at  $T_J = 150^\circ\text{C}$ .

The qualitative behavior of the thermal protection is shown in **Figure 5** in comparison to the characteristic of previous products. The advantage of the new protection scheme is constant light output even at temperatures as high as  $100^\circ\text{C}$  followed by a steep reduction of current at higher temperatures, leading to better protection of the application.

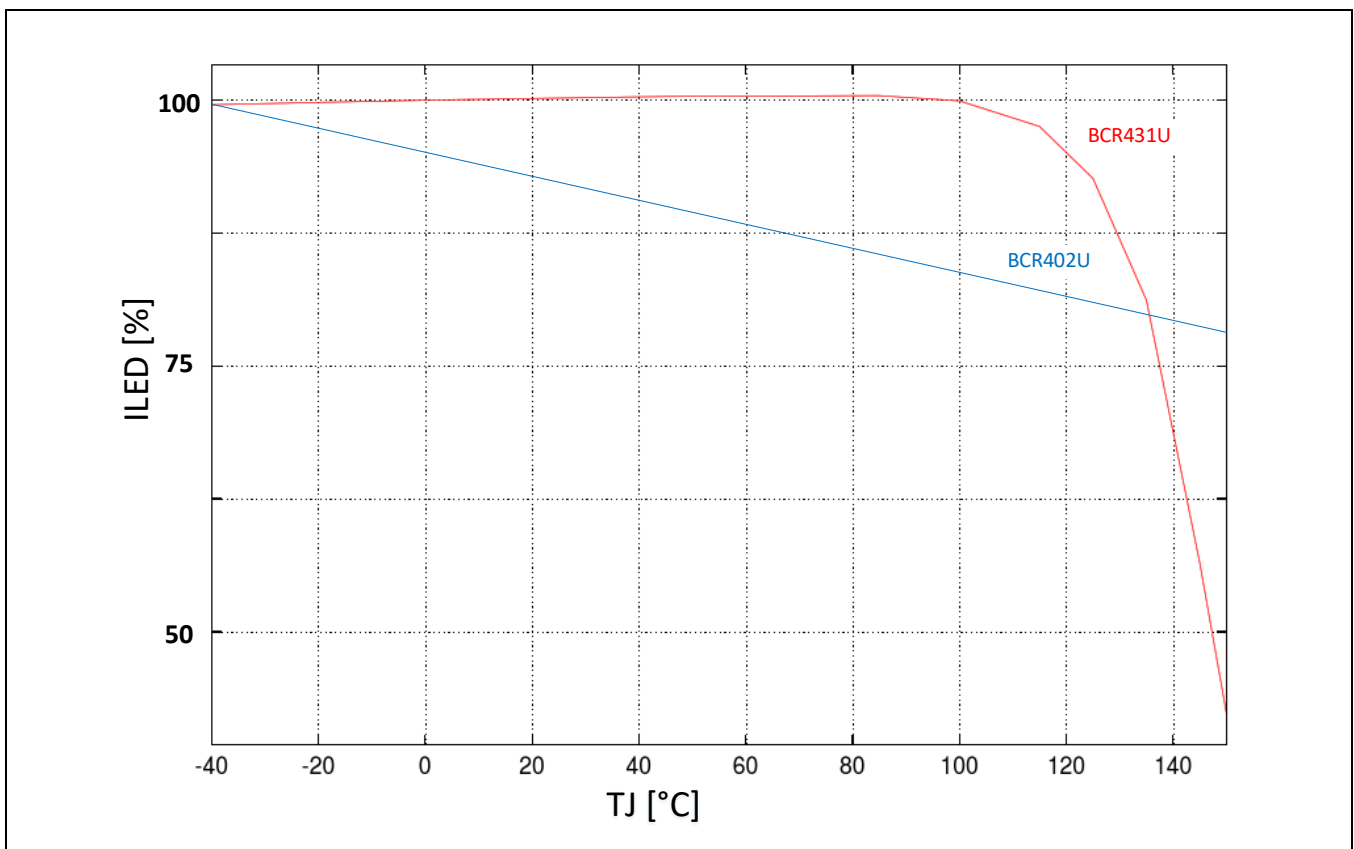

**Figure 5** Overtemperature protection characteristics of BCR431U compared to BCR402U

The power dissipation of the controller is determined by:

$$P_{diss} = (V_{IN,max} - n \cdot V_{LED,min}) \cdot I_{LED}$$

### BCR431U application

In this equation  $V_{IN,max}$  is the maximum supply voltage determined by the maximum positive tolerance of the power supply, including low-frequency ripple, and  $V_{LED,min}$  is the minimum LED forward voltage at the given temperature. All other values have been defined before. The temperature rise of the IC is then given by the equation

$$\Delta T = P_{diss,max} \cdot R_{thJA}$$

where  $R_{thJA}$  is the thermal resistance junction to ambient. The latter depends on the area of PCB traces the device is connected to. Values for different PCB areas are given in the datasheet. The maximum permissible temperature rise  $\Delta T_{max}$  for a given application can be determined from the fact that the maximum junction temperature should be below 100°C at maximum ambient temperature  $T_{amb,max}$ .

This finally leads to the condition:

$$R_{thJA} \leq \frac{100\text{ }^{\circ}\text{C} - T_{amb,max}}{P_{diss,max}}$$

#### Example:

$V_{IN,max} = 25\text{ V}$ ,  $V_{LED,min} = 2.9\text{ V}$ ,  $n = 7$ ,  $I_{LED} = 35\text{ mA}$  and  $T_{amb,max} = 70^{\circ}\text{C}$ . Then

$$R_{thJA} \leq \frac{30\text{ }^{\circ}\text{C}}{0.035 \cdot (25\text{ V} - 7 \cdot 2.9\text{ V})} = \frac{30\text{ K}}{0.164\text{ W}} \approx 180\frac{\text{K}}{\text{W}}$$

Which, according to the datasheet, is the thermal resistance with 300 mm<sup>2</sup> PCB area connected to the ground pin.

### 3 Advanced BCR431U design topics

#### 3.1 Maximum strip length

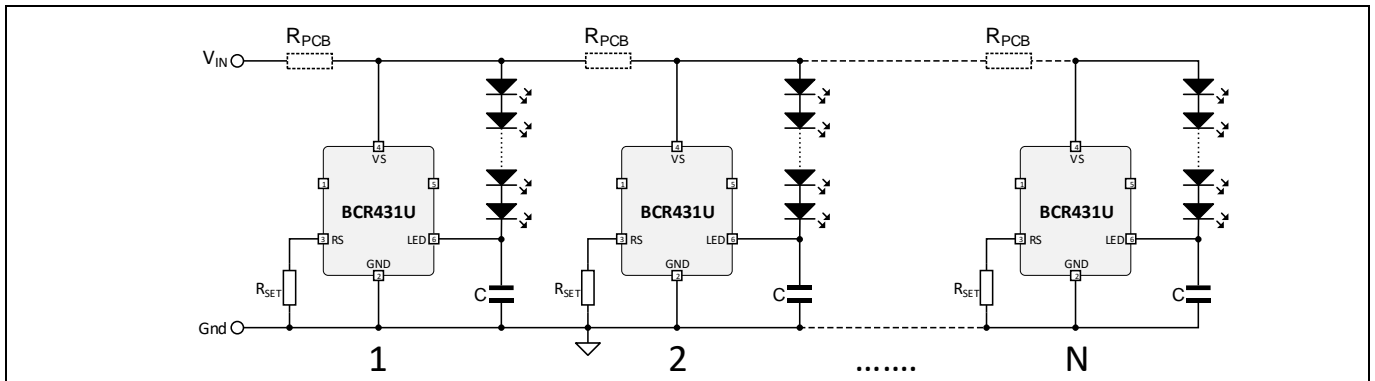

**Figure 6** In an LED strip N strings of LEDs are in parallel, connected by PCB traces with resistance  $R_{PCB}$

LED strips have a limited length due to the voltage drop along the copper traces. To increase the length of a strip either the number of LEDs in each string is reduced in order to have enough voltage headroom, or at a certain strip length an additional supply point is needed. The first approach increases losses in the regulator, while the second adds effort and cost. Low-drop regulators help to increase the strip length for a given number of LEDs in a string.

As shown in **Figure 6** and **Figure 12** (section 4), the first copper trace conducts the sum of the currents of all following strings, the second copper trace conducts one  $I_{LED}$  less, and so on. The total voltage drop measured from the supply point to the N-th string is:

$$V_{PCB} = R_{PCB} \cdot I_{LED} \cdot (1 + 2 + \dots + N) = R_{PCB} \cdot I_{LED} \cdot N \cdot (N + 1)$$

The final formula for maximum strip length is given in section 4.

[The LED strip length calculation tool](#) can make calculating the maximum number of segments and maximal length very easy.

#### 3.2 Reverse polarity protection

In some applications reverse polarity protection is needed. However, the obvious solution, to put a properly oriented diode in series with the positive supply rail, might lead to a high voltage drop, even if a Schottky diode is used.

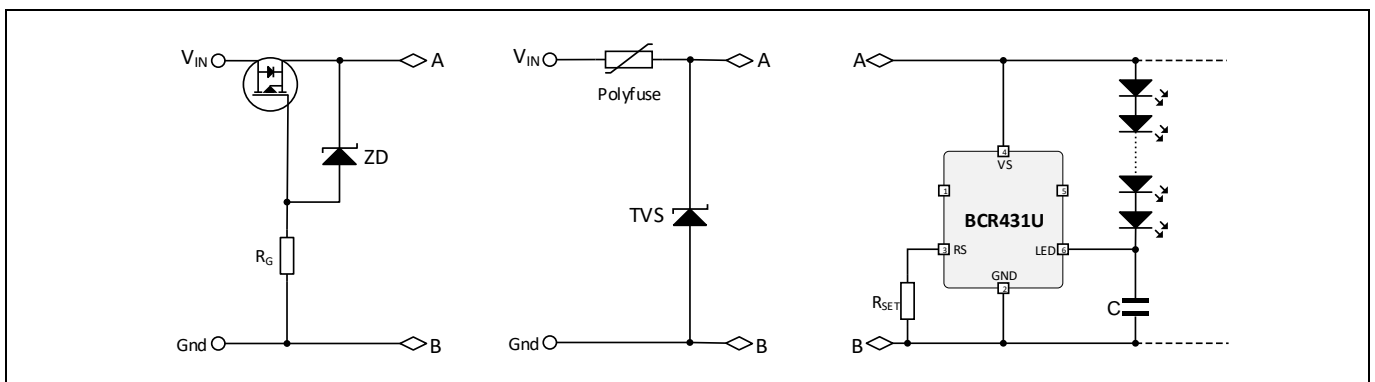

**Figure 7** Two low-drop solutions for reverse polarity protection



Two possible solutions are shown in **Figure 7**. The first uses a PMOS with a gate protection circuit consisting of a resistor and a Zener diode. In this circuit voltage drop depends on  $R_{DS,on}$  of the MOSFET, and can be much smaller than that of a diode. The breakdown voltage of the MOS needs to be higher than the highest expected reverse voltage, and the breakdown voltage of the Zener diode needs to be smaller than maximum gate voltage of the MOSFET but higher than its  $V_{GS,th}$ .  $R_G$  can be in the order of some tens of  $k\Omega$ . For example, a good choice for the MOSFET is IRF5803TRPBF, having a  $V_{DS,max}$  of -40 V and an  $R_{DS,on}$  of 190 m $\Omega$  at  $V_{GS} = -4.5$  V and 112 m $\Omega$  at  $V_{GS} = -10$  V. The breakdown voltage of the Zener diode should then be 10 V and the resistor 10 k $\Omega$ .

The second circuit uses a polyfuse together with a TVS. When wrong polarity is applied, the TVS is forward biased and effectively short-circuits the supply. Due to increased current the polyfuse will go into a high-ohmic state, limiting the current to small values. The advantage of this solution is that a properly selected TVS, i.e. having a breakdown voltage only slightly higher than the maximum expected supply voltage, will also make the system very robust against over-voltage and surge events.

In the rare case that reverse polarity protection is needed and the strip can be cut to length between the segments, each segment needs to be protected by a Schottky diode, as shown in **Figure 8**. A good choice for  $D_1$  to  $D_N$  would be BAS40LP, for example, having a maximal breakdown voltage of 40 V and maximal current of 120 mA.

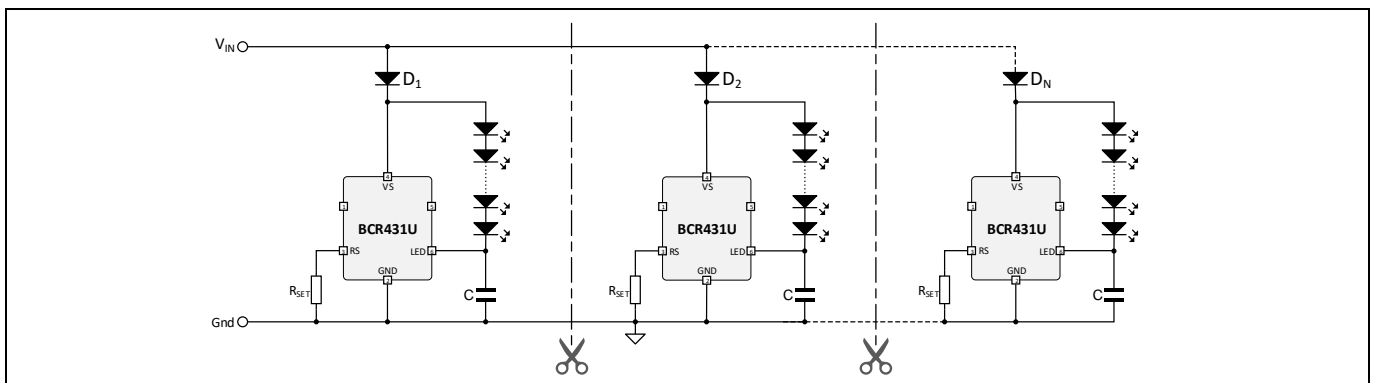

**Figure 8** Reverse polarity protection if strip can be cut between segments

### 3.3 Dimming

Virtually all dimmable LED drivers designed to drive LED strips, i.e. with CV output, employ dimming by PWM of the output voltage. This method enables 1 percent of dimming at 400 Hz. For cost reasons, often the PWM is created by a single switch in series to the output, without active pull-down. That means the output voltage drops to zero by a time constant defined by the system and therefore, if duty cycle is high, it may not even reach zero before the next turn-on.

To ensure proper operation of BCR431U with PWM,  $V_S$  must drop below 6 V before the next turn-on of  $V_{IN}$ . This is supported by the circuit in **Figure 9**. In this circuit  $V_S$  is around 9 V and will quickly fall below 6 V even at high duty cycles.

Dimming via  $R_S$  pin is possible as well, either by a PWM signal or a DC voltage. The PWM signal may be generated by a microcontroller. Its amplitude must not exceed  $V_{RS,max}$  level to avoid damage. This method enables 1 percent of dimming at 1 kHz.

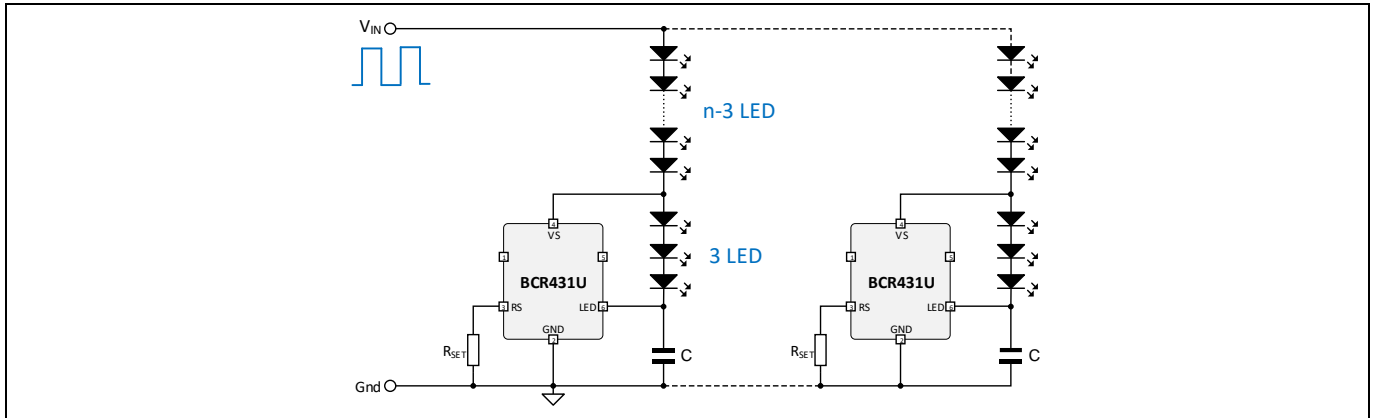

**Figure 9 Dimming by PWM of supply voltage**

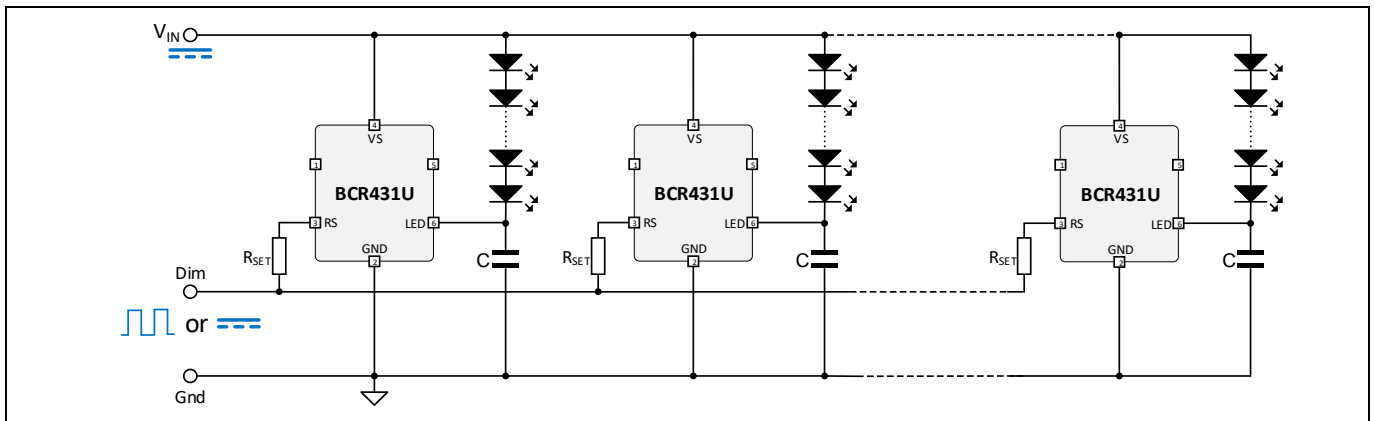

**Figure 10 PWM or analog dimming via RS pin**

### 3.4 System ESD

Internal ESD is durable to protect the VS pin on the system level up to 4 kV. For higher ESD robustness, it is recommended to limit ESD surge by external components such as a 100 nF ceramic capacitor, as shown in [Figure 11](#).

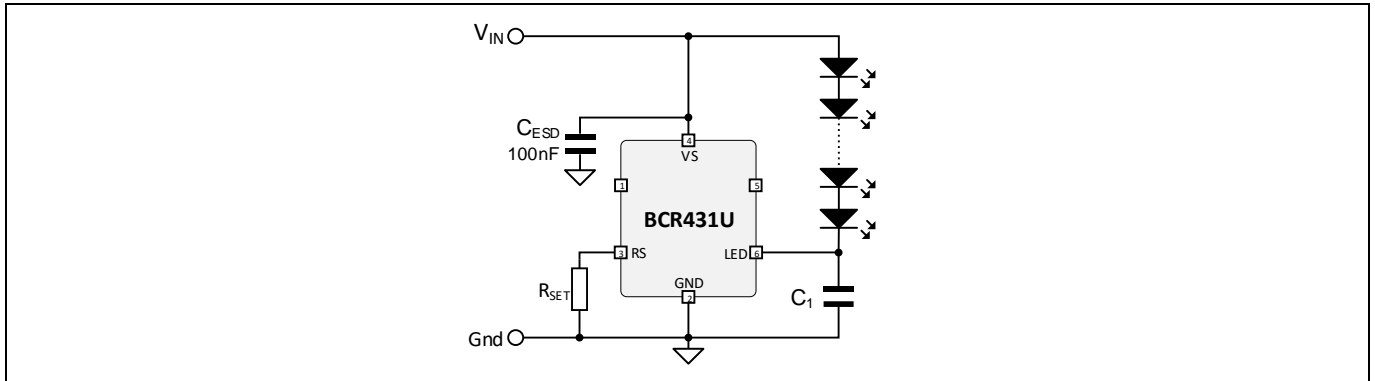

**Figure 11 ESD protection with external components for harsh surge environments**

## 4 Appendix: maximum strip-length calculation

As described in section 3, the length of the strip is, among other factors, limited by the voltage drop along the PCB traces of the strip. The supply voltage  $V_{STR}$  of the last string needs to be high enough to provide at least the minimum voltage drop  $V_{LED,sat}$  of the regulator.

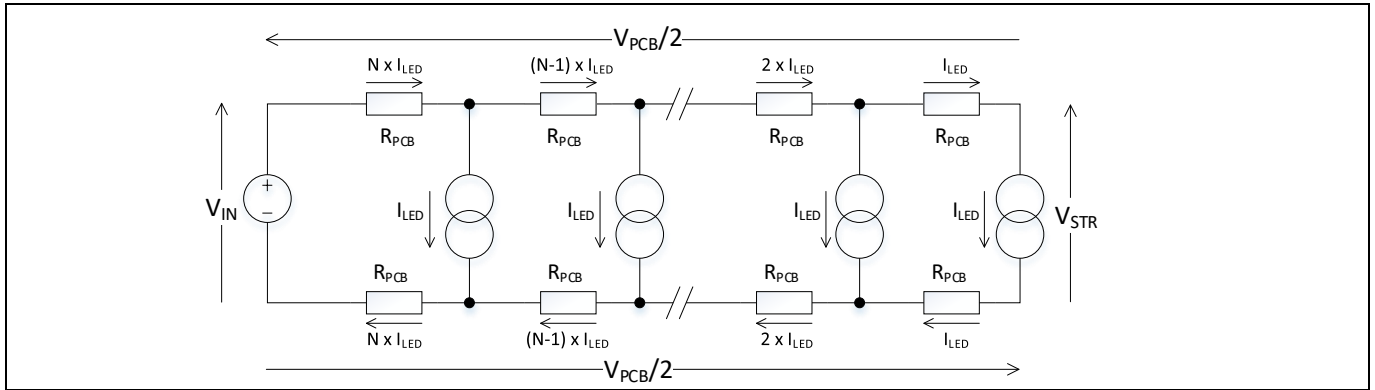

Figure 12 Definition of voltage drop across an LED string

$$V_{LED,sat} + n \cdot V_{LED,max} + V_{PCB} \leq V_{IN,min} \quad \text{with} \quad V_{PCB} = 2 \cdot R_{PCB} \cdot I_{LED} \cdot N \cdot (N + 1)$$

The factor of two is due to the fact that the positive and negative PCB trace contribute to the total resistance. Single segment copper resistance is:

$$R_{PCB} = \frac{\rho \cdot l}{t \cdot h}$$

( $l$  length of segment [m],  $t$  Cu width [mm],  $h$  Cu thickness [mm] and  $\rho$  specific resistance of Cu ( $0.0175 \frac{\Omega m}{mm^2}$ )).

From the above, a quadratic equation for  $N$  can be derived, having the solution:

$$N \leq \sqrt{\frac{V_{IN,min} - n \cdot V_{LED,max} - V_{LED,sat}}{2 \cdot R_{PCB} \cdot I_{LED}}} + \frac{1}{4} + \frac{1}{2}$$

The maximum length of the multi-segment LED strip is:  $L_{max} = N \cdot l$

### Example:

An LED strip of **50 mm** segment length, **3 mm** trace width and a copper thickness of **35  $\mu$ m** has a trace resistance of:

$$R_{PCB} = \frac{0.0175 \frac{\Omega m}{mm^2} \cdot 0.05m}{3mm \cdot 0.035mm} \cong 8.25m\Omega$$

With  $V_{IN,min} = 23 \text{ V}$ ,  $V_{LED,max} = 3.2 \text{ V}$ ,  $n = 6$ ,  $V_{LED,sat} = 0.2 \text{ V}$  and  $I_{LED} = 35 \text{ mA}$ , the maximum number of segments will be:

$$N \leq \sqrt{\frac{23V - 6 \cdot 3.2V - 0.2V}{0.0165\Omega \cdot 0.035A}} + \frac{1}{4} + \frac{1}{2} = 79.45$$

This makes a maximum number of 79 segments. The total length of the strip would be  $79 \cdot 0.05 \text{ m} = 3.95 \text{ m}$

### Appendix: maximum strip-length calculation

With all the above parameters unchanged but  $V_{LED,sat} = 1.5\text{ V}$  the maximum number of segments changes to:

$$N \leq \sqrt{\frac{23\text{V} - 6 \cdot 3.2\text{V} - 1.5\text{V}}{0.0165\Omega \cdot 0.035\text{A}}} + \frac{1}{4} + \frac{1}{2} = 63.61$$

i.e.  $N = 63$ . The length of the strip would be  $63 \cdot 0.05\text{ m} = 3.15\text{ m}$ ; this is 16 segments, equivalent to 0.8 m, less than before.

## **5 Revision history**

| <b>Document version</b> | <b>Date of release</b> | <b>Description of changes</b> |
|-------------------------|------------------------|-------------------------------|
| V 1.0                   | 31-03-2020             | First release                 |
|                         |                        |                               |
|                         |                        |                               |

**Trademarks**

All referenced product or service names and trademarks are the property of their respective owners.

**Edition 2020-03-31**

**Published by**

**Infineon Technologies AG**

**81726 Munich, Germany**

**© 2020 Infineon Technologies AG.**

**All Rights Reserved.**

**Do you have a question about this document?**

**Email: [erratum@infineon.com](mailto:erratum@infineon.com)**

**Document reference**

**AN\_1909\_PL39\_1911\_081848**

**IMPORTANT NOTICE**

The information contained in this application note is given as a hint for the implementation of the product only and shall in no event be regarded as a description or warranty of a certain functionality, condition or quality of the product. Before implementation of the product, the recipient of this application note must verify any function and other technical information given herein in the real application. Infineon Technologies hereby disclaims any and all warranties and liabilities of any kind (including without limitation warranties of non-infringement of intellectual property rights of any third party) with respect to any and all information given in this application note.

The data contained in this document is exclusively intended for technically trained staff. It is the responsibility of customer's technical departments to evaluate the suitability of the product for the intended application and the completeness of the product information given in this document with respect to such application.

For further information on the product, technology, delivery terms and conditions and prices please contact your nearest Infineon Technologies office ([www.infineon.com](http://www.infineon.com)).

**WARNINGS**

Due to technical requirements products may contain dangerous substances. For information on the types in question please contact your nearest Infineon Technologies office.

Except as otherwise explicitly approved by Infineon Technologies in a written document signed by authorized representatives of Infineon Technologies, Infineon Technologies' products may not be used in any applications where a failure of the product or any consequences of the use thereof can reasonably be expected to result in personal injury.