

Quick Reference Guide

# Isolation in Electric Vehicle Systems



# Table of Contents

---

## EV Isolation Quick Reference Documents

Isolation in EV Battery Management Systems

Isolation in EV DC-DC Converters

Isolation in EV On-Board Chargers

Isolation in EV Traction Inverters

# Isolation in EV Battery Management Systems

EV BMS Isolation Quick Reference

Battery Management Systems (BMS) are used to monitor and control power storage systems, assure health of battery cells, and deliver power to vehicle systems. Isolation products have numerous uses inside BMS in the electrical domains of Electric Vehicles (EV) or Hybrid Electric Vehicles (HEV).

## BMS Overview

The systems in an EV are shown below. There are numerous modules that use Isolation such as: on-board chargers (OBC), BMS, dc-dc converters, traction inverters, engine control units, braking systems, transmissions, and heating/cooling units.

The BMS manages stored power in an on-board high voltage (HV) battery and delivers power to the rest of the vehicle.

The main functions include cell balancing, cell health and wear leveling, charge and discharge monitoring, and safety assurance.

All these functions require galvanic isolation to separate lower voltage systems from high voltage domains and offer design-in opportunities.

### Key Isolation Features for BMS

- 10+ years of automotive market experience, supporting automotive standards and customer needs
- Top isolation provider for OEMs and Tier 1 EV suppliers, over 30 million shipped
- Automotive-grade ready: AEC-Q100, enhanced manufacturing, and ultra-low defectivity

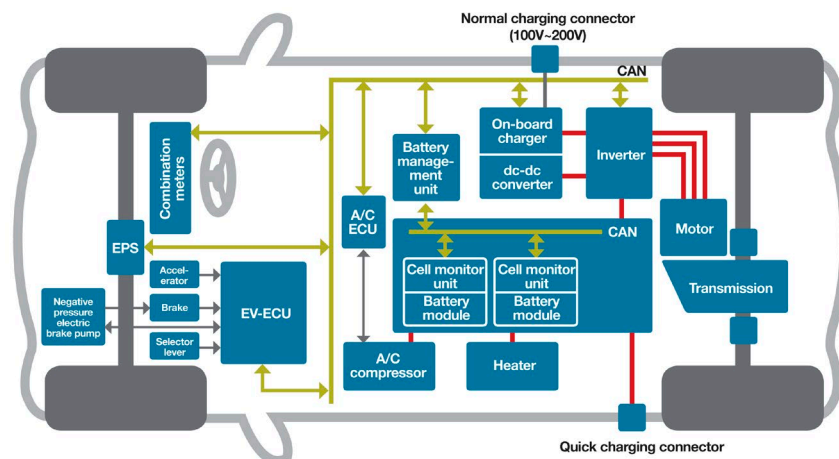

## BMS Module

EVs utilize BMS for the main battery-based power supply, and HEVs use BMS for battery-side portion of power, complimentary to the internal combustion engine (ICE). BMS monitors the voltage, current, temperature, and wear leveling of battery cells. Additional functions include monitoring faults, system health, available energy, and remaining useful lifetime. Individual lithium-ion battery cells are in the 3 – 4V range. They are connected in series to deliver higher voltage, and in parallel to increase capacity.

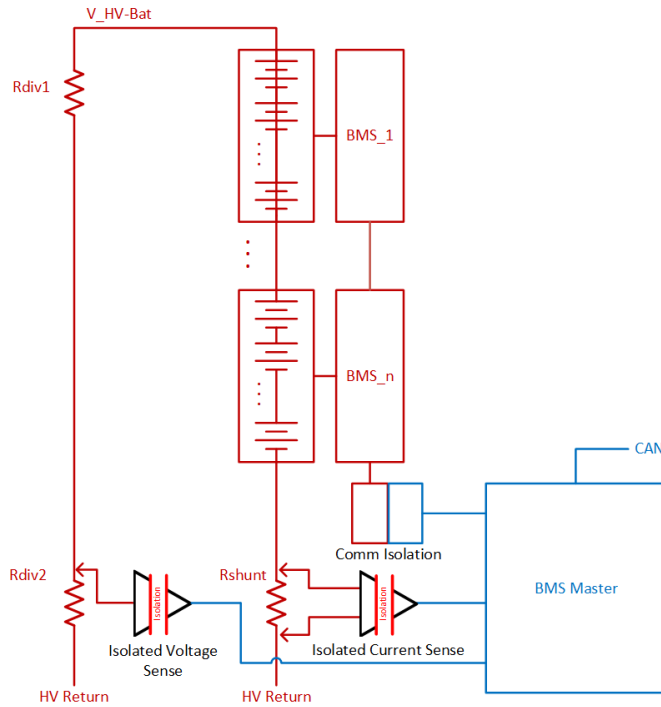

To monitor the modules and cells, the BMS may have a centralized architecture, or a distributed/modular architecture consisting of a BMS master and several remote BMS units. In distributed BMS systems, remote units monitoring individual cells may be connected in parallel to the BMS master, or they may be daisy-chained in series. In any case, connections from the battery modules or BMS remote units to the BMS master must be isolated to protect the BMS master from the battery voltages.

The diagram depicts a distributed BMS with multiple packs of cells, each with a remote BMS control unit. In this configuration, measurements on cells within the battery modules are made by the remote BMS units and reported over a series connection to the BMS Master controller. Current measurement for the full stack is made using a shunt resistor at the bottom of the stack and an isolated current amp like the [Si892x](#) or [Si894x](#). The BMS controller can calculate the voltage of the full stack by summing the voltages of the modules, but a redundant safety-check isolated voltage

measurement of the full stack can be made using a resistor divider and isolated voltage sense amp like the [Si893x](#).

The entire system can be monitored and controlled via an automotive bus such as CAN. The CAN is isolated with digital isolators like [Si86xx](#) and digital isolators with integrated dc-dc power converters like [Si88xx](#).

## Where Isolation is Needed

- **Voltage:** Assure safe and useful battery voltage output
  - Isolated voltage sensor for the full battery stack
- **Current:** Protect batteries from overload or high charging rates
  - Isolated current sensor monitors discharge and charge current
- **Communications:** CAN or serial bus for module data
  - Digital isolators enable safe and robust communication

## Isolation Product Offering Summary

Family	Purpose	Family	Purpose
<a href="#">Si86xx</a>	System communication	<a href="#">Si892x</a>	Amplifier for Current Shunt Measurement
<a href="#">Si88xx</a>	Communication with power transfer	<a href="#">Si894x</a>	Delta-Sigma Modulator for Current Shunt Measurement
<a href="#">Si893x</a>	Amplifier for Voltage Measurement		



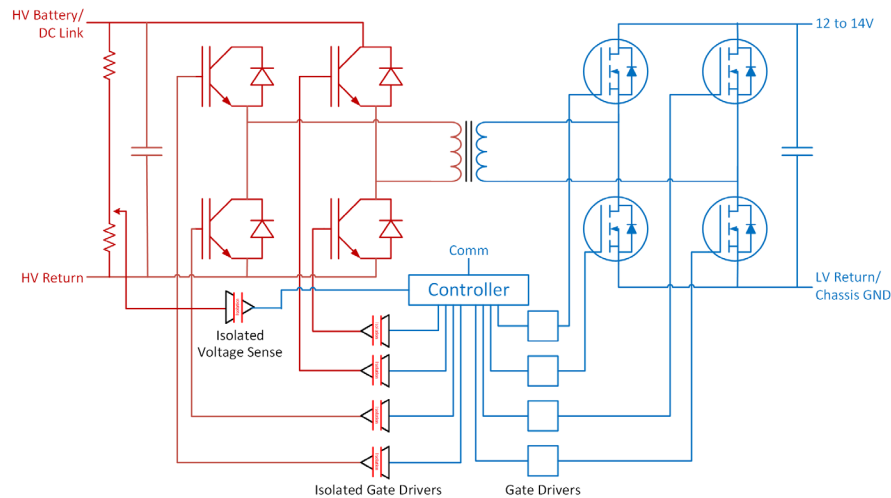

The APM depicted uses a full bridge on the high-voltage primary side of the transformer, and a full-bridge synchronous rectifier on the low-voltage secondary side of the transformer. The HV switches are often implemented as fast IGBTs (as shown) or high-voltage MOSFETs; the HV switches on the primary side of the transformer require isolated gate drivers. The gate drive for these switches uses isolated gate drivers like the [Si8239x](#), [Si823x](#), [Si823Hx](#), [Si827x](#), and [Si828x](#). The latest dc-dc converters are implemented using SiC MOSFETs to increase power density and reduce size.

The converter may be unidirectional, supplying energy only from the high-voltage domain to the low-voltage domain, or it may be bidirectional. While a unidirectional dc-dc can use diodes instead of switches on the LV side, a bidirectional module requires switches. However, gate drivers for the low-voltage switches generally do not need to be isolated.

The APM controller will also need to sense the input and output voltages of the converter to provide closed-loop control. The Si8931 isolated voltage sensor is well-suited for this purpose.

The entire system can be monitored and controlled via an automotive bus such as CAN (“Comm” in the diagrams). The CAN is isolated with digital isolators like Si86xx and digital isolators with integrated dc-dc power converters like Si88xx.

## Where Isolation is Needed

- **Converters:** Implemented with silicon FETs, IGBTs, or SiC FETs
  - Isolated gate drivers for the four high/low-side switches
  - Isolated voltage sensor for input and output of the converter
- **Communications and Sensing:** Data for closed-loop control
  - Isolators for digital CAN or other bus types

## Isolation Product Offering Summary

Family	Purpose	Family	Purpose
<a href="#">Si86xx</a>	System communication	<a href="#">Si8239x</a>	FET driver with enhanced safety features
<a href="#">Si88xx</a>	Communication with power transfer	<a href="#">Si823Hx</a>	FET driver with 4A drive strength and high CMTI
<a href="#">Si823x</a>	FET driver in switch and sync blocks	<a href="#">Si827x</a>	High CMTI Driver for SiC FETs
<a href="#">Si828x</a>	IGBT driver with integrated dc-dc	<a href="#">Si8931</a>	Isolated Voltage Sensor

# Isolation in EV On-Board Chargers

EV OBC Isolation Quick Reference

On-Board Chargers (OBC) are used to convert 120V or 240V AC from a wall socket or wall charger into a DC voltage for charging an automotive battery. Isolation products have numerous uses inside OBCs for Electric Vehicles (EV) and Plug-In Hybrid Electric Vehicles (PHEV).

### Key Isolation Features for OBC

- 10+ years of automotive market experience, supporting automotive standards and customer needs
- Top isolation provider for OEMs EV suppliers, over 30 million shipped
- Automotive-grade ready: AEC-Q100, enhanced manufacturing, and ultra-low defectivity

## EV System Overview

The systems in an EV are shown below. There are numerous modules that use Isolation such as: OBCs, Battery Management Systems (BMS), DC/DC converters, traction inverters, and heating/cooling units. The OBC converts AC power from an external charging source into a DC voltage that is used to charge the battery pack in the vehicle.

In addition, the OBC performs other functions including charge rate monitoring and protection. Key standards and terminology are shown in the table below. AC Level 2 OBCs and some Level 1 require isolation. Note that with DC Fast Chargers—which plug in the Quick charging connector—the OBC is bypassed, but such external AC/DC converter stations are also an Isolation design-in opportunity!

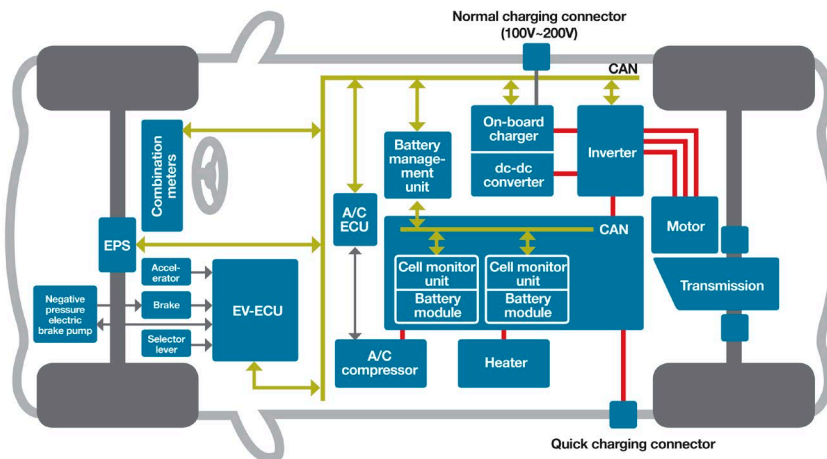

terminology are shown in the table below. AC Level 2 OBCs and some Level 1 require isolation. Note that with DC Fast Chargers—which plug in the Quick charging connector—the OBC is bypassed, but such external AC/DC converter stations are also an Isolation design-in opportunity!

Parameter	Charging Standards			EV Supply Connector	Regions
Level	AC Level 1	AC Level 2	DC Fast Charge	CHAdeMO	Japan
Voltage	120V	220V or 208V	480V	J1772/CCS	Americas, Europe
Current	15A max	40A max	125A max	GB/T	China

## OBC System

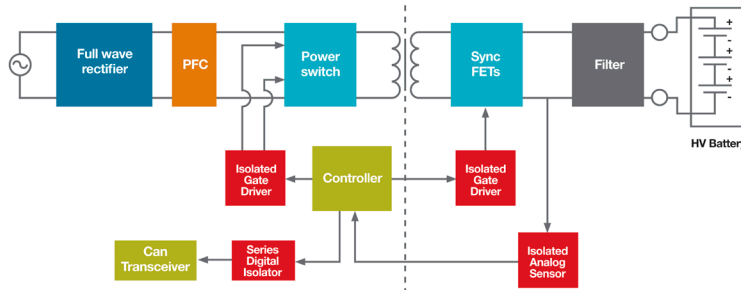

### Isolation Solutions in OBC

- Si86xx and Si88xx digital isolators for communication buses like CAN and SPI
- Si82xx isolated gate drivers for driving currents into the transformer and synchronizing for DC/DC conversion efficiency
- Si892x/3x/4x isolated analog sensors for monitoring charging current or battery voltage for closed-loop control

The OBC system takes the AC input source, converts it to high voltage DC through the rectifier and provides Power Factor Correction (PFC). The resulting DC signal is chopped into a switched square wave to drive a transformer to create the required output DC voltage. The chopping of the input signal is accomplished using isolated gate drivers like the [Si8239x](#), [Si823x](#), [Si823Hx](#), and [Si827x](#).

The output voltage is filtered to the final DC voltage using sync FETs under the control of additional isolated gate drivers. The output voltage can be monitored to provide closed-loop feedback to the system controller using isolated analog sensors like the [Si892x](#), [Si8931](#), and [Si894x](#).

The entire system can be monitored and controlled via an Isolated CAN bus. The CAN is isolated with digital isolators and digital isolators with integrated DC/DC power converters like the [Si86xx](#) and [Si88xx](#).

## Why Silicon Labs

- Broad portfolio
  - Rich variety of digital isolators, isolated gate drivers, and current sensors
  - Pin-compatible, second-source options for many popular products
- Robust qualification and support
  - Fully compliant AEC-Q100 qualification
  - Documentation: PPAP, CAMDS, IMDS
- Excellent technical performance
  - EMI reports help ensure customers will pass regulatory tests
  - Industry-leading common mode transient immunity (CMTI)

## Isolation Product Offering Summary

Family	Purpose	Family	Purpose
<a href="#">Si86xx</a>	System communication	<a href="#">Si8239x</a>	FET driver with enhanced safety features
<a href="#">Si88xx</a>	Communication with power transfer	<a href="#">Si823Hx</a>	FET driver with 4A drive strength and high CMTI
<a href="#">Si823x</a>	FET driver in switch & sync blocks	<a href="#">Si827x</a>	High CMTI Driver for SiC and GaN FETs in sync FET block
<a href="#">Si8931</a>	Voltage measurement amplifier	<a href="#">Si892x/4x</a>	Current shunt sense amplifiers with digital or analog output



# Isolation in EV Traction Inverters

EV Traction Inverter Quick Reference

Traction inverters are used to convert stored dc high voltage from a battery or dc bus link into multi-phase ac power for driving a traction motor. Isolation products have numerous uses inside traction inverters in the drivetrain of Electric Vehicles (EV) or Hybrid Electric Vehicles (HEV).

## EV System Overview

The systems in an EV are shown below. There are numerous modules that use Isolation such as: on-board chargers (OBC), Battery Management Systems (BMS), dc-dc converters, traction inverters, and heating/cooling units.

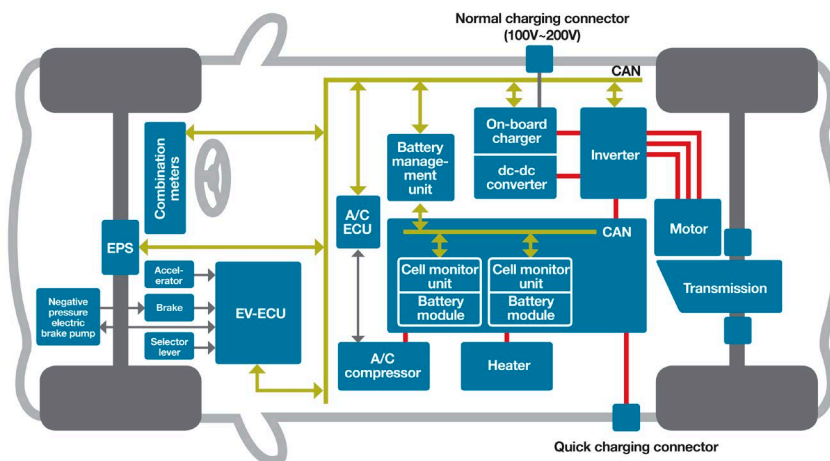

**Key Isolation Features for Traction Inverters**

- 10+ years of automotive market experience, supporting automotive standards and customer needs
- Top isolation provider for OEMs & EV suppliers, over 30 million shipped
- Automotive-grade ready: AEC-Q100, enhanced manufacturing, and ultra-low defectivity

The traction inverter converts dc power from an on-board high voltage (HV) battery into ac power to drive the main motor or motors of an electric vehicle.

In addition, traction inverters perform functions such as voltage boosting, switch protection, and regenerative braking support.

All these functions require galvanic isolation to separate control systems from high voltage domains and offer design-in opportunities.

## Traction Inverter System

EVs and HEVs require a traction inverter to convert dc energy from the high-voltage battery or dc link bus to the three-phase ac energy used to drive the traction motor. The traction inverter is typically capable of transferring power in the 20 to 100 kW range, with switching voltages in the 200 to 800V range, and currents in the hundreds of amperes.

The entire system can be monitored and controlled via an automotive bus such as CAN ("Comm" in the diagrams). The CAN is isolated with digital isolators like Si86xx and digital isolators with integrated dc-dc power converters like Si88xx.

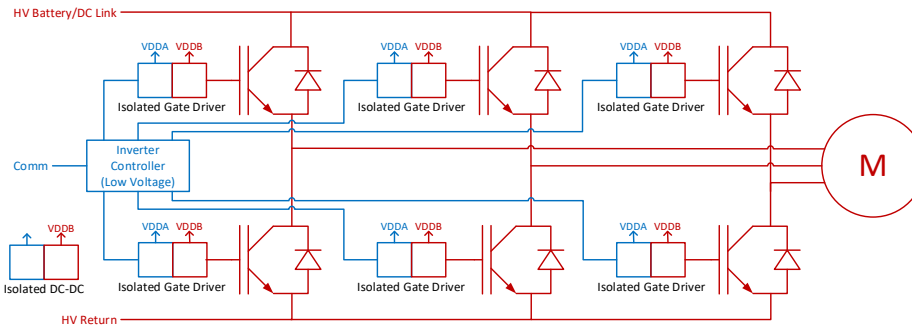

The traction inverter function is accomplished using six switches; one high-side, and one low-side switch for each phase. Isolation separates the controller domain from the high-voltage ac domain. The gate drive for these switches uses isolated gate drivers like the [Si8239x](#), [Si823x](#), [Si823Hx](#), [Si827x](#), and [Si828x](#). The output side of the isolated gate drivers require a supply (typically 15 to 30 Vdc for IGBTs) that is isolated from the low-voltage domain and can be provided by the built-in dc-dc converter in the [Si828x](#) IGBT driver family.

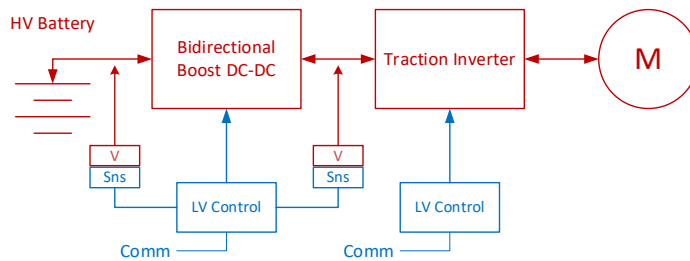

Getting optimal efficiency from the system may require peak ac voltages that exceed the vehicle's HV battery voltage, so the traction inverter is often preceded by a bidirectional dc-dc boost converter. This boost converter often contains 2 switches, which require isolated gate drivers. The system voltages can be sensed before the booster and traction inverter and a measurement taken with the [Si8931](#) isolated sensor ("Sns" in the diagram).

HEVs also include a generator that converts mechanical energy from the internal combustion engine (ICE) into electrical energy to recharge the battery when the ICE is running. A block diagram for the generator's ac-dc converter looks the same as the traction inverter, with the motor ("M") replaced with a generator and the power flowing from generator towards the HV battery. Isolated gate drivers are needed for the switches.

## Where Isolation is Needed

- **Inverter:** Solutions available for silicon FETs, IGBTs, or SiC FETs
  - Isolated gate drivers for the six high/low-side switches
- **Booster:** Optional dcdc booster to increase HV battery voltage
  - Isolated gate drivers needed for 2 switches
- **Generator (Hybrid):** Recharges battery when ICE is running
  - Isolated gate drivers for high/low-side switches

### Additional Inverter Types

- HVAC compressors, oil and water pumps, PTC heaters, and turbo chargers may run from HV
- These auxiliary inverters also present opportunities for isolation design-in

## Isolation Product Offering Summary

Family	Purpose	Family	Purpose
<a href="#">Si86xx</a>	System communication	<a href="#">Si8239x</a>	FET driver with enhanced safety features
<a href="#">Si88xx</a>	Communication with power transfer	<a href="#">Si823Hx</a>	FET driver with 4A drive strength and high CMTI
<a href="#">Si823x</a>	FET driver in switch & sync blocks	<a href="#">Si827x</a>	High CMTI Driver for SiC FETs
<a href="#">Si828x</a>	IGBT driver in Inverter Block	<a href="#">Si826x</a>	MOSFET/SiC FET driver with diode input