

Convergence of 5G, Fast Charging and USB-C™ Programmable Power Supplies

Author: [Bob Card](#)

Introduction

Consumers shook their heads when 100W (USB3.0) charging was introduced in 2016. “Who would ever need that much power, when most smartphones can charge on 10W?” Well, if the wave of recent 5G phones released in 2020 is any indication of things to come, 45W smartphone chargers will be common place. And as charging power goes up, so does the importance of efficiency. [USB-C](#) (also known as USB Type C)’s latest PD 3.0 specification, specifically Programmable Power Supplies (PPS), is by far the most efficient charging solution on the market, and for that reason, will become the preferred choice for charging tomorrow’s smart phones, tablets and laptops.

PD 3.0 (PPS) Advantages over PD 2.0

PD 2.0 allows a maximum limit of 7 Power Data Objects (PDOs), used to expose a source port’s power capabilities or a sink’s power requirements, transmitted within a PD message across the USB-C, CC pin. In contrast, PD 3.0, PPS offer a “range of voltage and current” PDO’s described in Figure 1. The PPS advantage is the sink can request voltage/current in “finer granularity” vs. Fixed PDO’s. This helps optimize the charging efficiency between the source and the sink.

PD Specification:	Power Capabilities	Voltage (V):	Current (A):
2.0	Fixed PDO’s	5, 9, 15, 20	3A, 5A
3.0	PPS (Programmable Power Supply)	3.3 – 21, 20mV steps	Up to 5A, 50mA steps

Figure 1

5G Smartphone Battery Size

A recently released 5G smartphone comes with a 6.9 inch screen and a li-ion battery capacity of 5,000mAh, a 25% increase in capacity vs the previous model. I suspect both screen size and 5G play a role in the battery size increase. But, either way, a 25% increase in battery size means more power required from the ACDC Travel Adaptor (TA), in order to continue claiming “Fast Charging”. And the USB -C PPS is the logical choice for accomplishing this.

Fast Charging

The phrase “Fast Charging” gets tossed around a lot. Traditionally, li-ion charging was safely accomplished at a 0.7 C-Rate. C-rate is simply the charge current divided by the cell capacity. For example a 0.7 C-rate charge current for a 1,000mAh cell is 700mA. But, typically it takes ~45 minutes (Figure 2) Time to Charge (TTC) to charge an empty cell from 0% to 50% State of Charge (SoC). That is not so fast. And, you can’t simply “crank up the current” to improve the TTC. Charging a cell at 1-C-rate, when its data sheets say it is specified for 0.7 C-rate will cause the cell to age prematurely, or possibly cause permanent damage. And remember, per their data sheets, Li-ion cells must retain a minimum of 80% of its original capacity, after a minimum of 500 cycles.

Faster Time to Charge (TTC) Means More Power

In order to improve TTC, cell manufactures are designing cells for >1C rate charging, or faster charging. This mainly entails lowering the cell’s internal impedance in order to lengthen the time the charge profile remains in Constant Current (CC) mode (assuming you start charging with an empty cell) before the cell voltage reaches its max voltage, and the charge profile transitions to Constant Voltage (CV) mode. As you can see in Figure 2, one can reduce the 0-50% SoC TTC by 15 minutes, by charging at 1C-rate vs. 0.7C-rate, and even faster, to 22 minutes with a 1.5C-Rate. However, 1.5C-rate of a 5000mAh cell requires 7.5A charging and 32.6W peak charge power (4.35V x 7.5A) at the battery. That’s a lot of power in a small space.

Charge Rate:	Battery Capacity:	Charge Current (I _{bat}):	Time to Charge (0-50% SoC):	Peak Charge Power:
0.7C	5000mAh	3.5A	~45min	15.2W
1C		5A	~30min	21.7W
1.5C		7.5A	~22min	32.6W
2C		10A	~15min	43.5W

Figure 2

I am not privy to the actual charge profile inside of the recently released 5G smartphone, but it does ship with a 25W PPS charger, and advertises the phone accepts a 45W PPS charger accessory (Figure 3). If I start with a 45W travel adaptor and assume ~80% efficiency (ball park) from the wall to the battery, that leaves me with ~36W going into the battery. ~36W is not very far off from the calculated 32.6W required for ~22 minute, 0% to 50% SoC, Time to Charge, highlighted in Figure 2 above.

One comment worth making is since the USB-C connector max current is 5A, in order to achieve 7.5A IBAT, a “divide by 2” charge pump would be required between USB Type-C connector and the battery charger, inside the 5G phone. For example, the TA might output 10V/4A, and the charge pump will output 5V/8A (assuming ideal power losses). This is sometimes referred to as HVLC (High Voltage, Low Current). As physics teaches us, power dissipation is I^2R , so there are benefits to shipping the power from the TA to the phone (~1meter cable) as HVLC, vs LVHC (Low Voltage High Current). And with the arrival of the Type C connector, USB-C PD 2.0 increased the VBUS max voltage from 5V to 20V, enabling the HVLC approach.

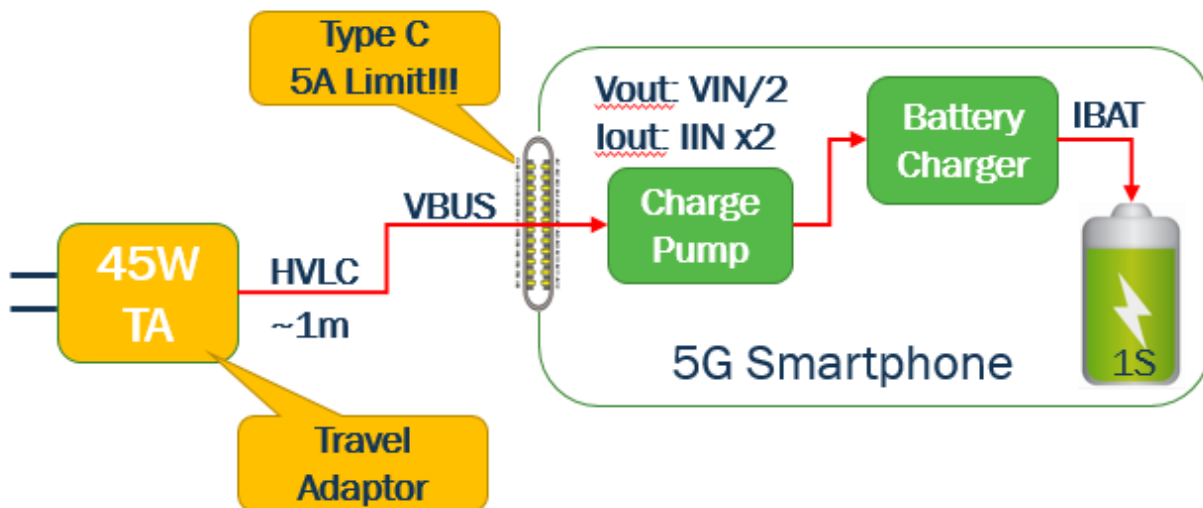

Figure 3

Sniffing a Laptop PD 2.0 Traffic

I may not be able to measure the actual 5G smartphone IBAT current between the battery charger and the battery, but I can measure the VBUS voltage and current (IBUS) between the TA and the 5G smartphone with a PD sniffer by Total Phase®. But before I do that, let’s sniff VBUS/IBUS for PD 2.0 between a laptop and the [FUSB3307 USB Power Delivery 3.0 Adaptive Source Charging Controller](#) 60W evaluation board (EVB) Source illustrated in Figure 4 below.

In this setup, a 5A cable is used between the laptop PD 2.0 sink, and the FUSB3307 EVB PD 3.0 Source. The Total Phase sniffer is inserted in series with the FUSB3307 EVB and the 5A cable. After attach, the FUSB3307 EVB advertises its source capabilities, in the form of four fixed PDO's and three PPS (Augmented) PDO's. The laptop requests the fixed PDO with 20V/3A, but only requires a maximum of 1.5A. The FUSB3307 accepts the laptop's request and the power contract is completed. In Figure 5, you can see VBUS (red) step to 20V, and as the laptop boots up (starting from an empty battery) the dynamic IBUS current (blue) ramps up to ~ 1.3A, or ~30W.



Figure 4

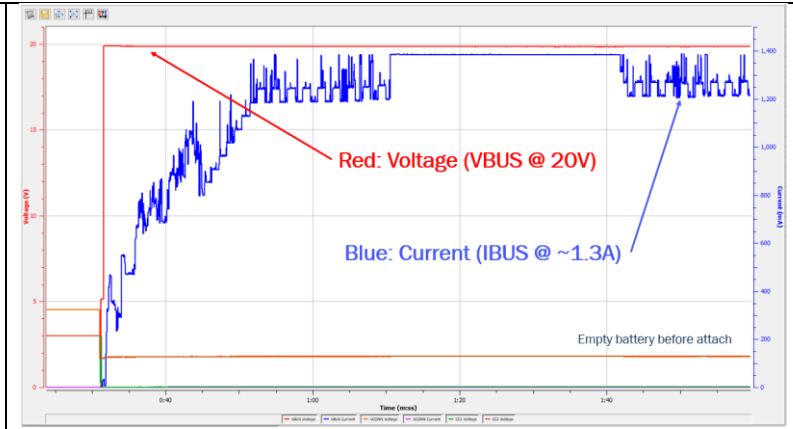

Figure 5

Sniffing the 5G Smartphone PD 3.0 PPS Traffic

Now let's turn our attention to Figures 6 and 7 where I replace the laptop with the 5G smartphone, and the source with a 100W FUSB3307 PD 3.0 PPS EVB. The 5G smartphone initially requests, and is granted a 5V fixed PDO, but then ~7 seconds later the 5G smartphone requests, and is granted a PPS (3V to 21V / 5A) PDO. The 5G smartphone immediately enters an algorithm whereby every 210msec it increments its requested voltage (red) from 8V to 9.28V, in 40mV steps, while ramping (sinking) current (blue) from 2A to 4A in the span of ~7 seconds. And the 5G smartphone continues communicating with the FUSB3307 source throughout the entire charge process.

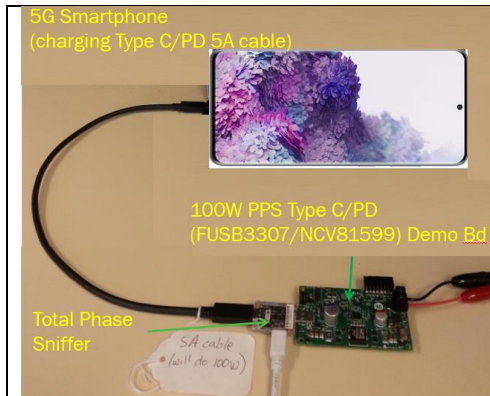

Figure 6

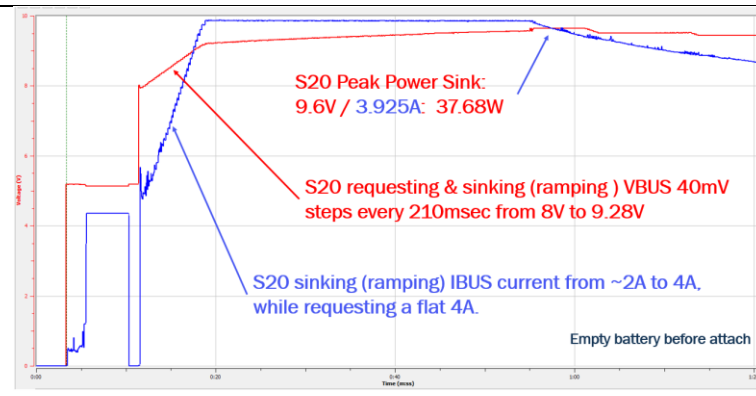

Figure 7

5G Smartphone PD 3.0 vs. Laptop PD 2.0 Traffic

The PD 2.0 traffic exhibited by the Laptop, while effective, is relatively simplistic. Within the 1st second of attach, a 20V/1.5A power contract is negotiated and granted, and no further PD traffic is observed. The 5G smartphone with PPS behaves completely different. The 5G smartphone is the master of a sophisticated algorithm, where it constantly instructs the FUSB3307 source to change its voltage output, as the 5G smartphone artfully ramps its load current.

The 5G smartphone/FUSB3307 peak power is observed ~60 seconds after attach at 37.68W (9.6V/3.925A). This is not too far from my estimated power required to charge the battery at 1.5C rate, or 32.6W at the battery (Figure 2), in order to achieve a ~22 minute (0% to 50% SoC) TTC. Now that is fast charging.

The “A, B, C’s” of Efficient Fast Charging, and PPS

5G and larger screens are driving larger smart phone batteries, which, coupled with customer’s expectations for “Fast Charging”, is demanding more power from the travel adaptor, to the tune of 45W, in the case of a recently released 5G smartphone. However, an increase in power dissipation will track this increase in power, in the form of heat. So, efficiency now becomes even more critical than ever, and that is where PPS comes in.

If we examine the generic “Wall to Battery” li-ion charging block diagram of Figure 8, the goal is to provide power to the system, through the PMIC, and in parallel, via the power path FET, charge the 1S cell from empty (~3V) to full (4.35V). No matter the technology (switching, Linear or Bypass), the Battery Charger will always perform at a higher efficiency if its input voltage (B) is slightly above its output voltage (C), or VBAT. And to complicate things, VBAT is always a moving target, for two reasons:

- 1) The battery voltage rises during the charge profile from empty to full, and
- 2) The battery voltage rises and falls as the asynchronous load varies.

In order to optimize the efficiency, the Travel Adaptor (TA) output (A) voltage needs to be tightly controlled by the Sink’s MCU, which now becomes the “charging algorithm master”. Between reading VBAT via the fuel gauge, and sensing the charge pump VOUT, the MCU Policy Manager can tightly control the TA VOUT w/ PD protocol messaging across the CC pin, with 20mV granularity (PPS).

With the addition PPS, mobile devices can now charge larger batteries, faster, safer, and more efficiently. The FUSB3307 EVB (Figure 9) successfully supports the 5G smartphone’s sophisticated PPS charging algorithm.

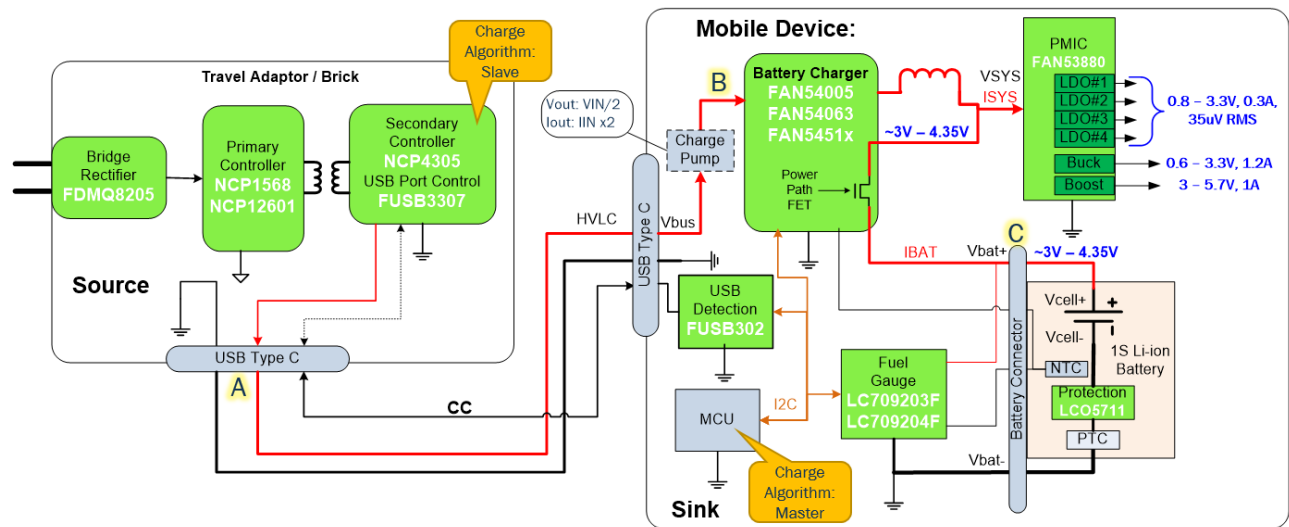

Figure 8

FUSB3307 Evaluation Board (EVB)

The FUSB3307 EVB accepts a 4.5V to 32V DC input, and provides 5V – 20V USB PD outputs, compliant to both PD 2.0 and PD 3.0 specifications, including with Programmable Power Supplies (PPS). The FUSB3307 is a state machine based PD Controller and USB-C port controller. Therefore no MCU required, and no firmware development is required. And no firmware means tamper prove, which can be beneficial in medical applications. Simply solder it down and it autonomously runs. The FUSB3307 state machine includes the PD Policy Manager, and controls the

[NCV81599 Buck boost](#) by driving the Comp input with the FUSB3307 CATH output pin. The FUSB3307 also autonomously controls the VBUS FET.

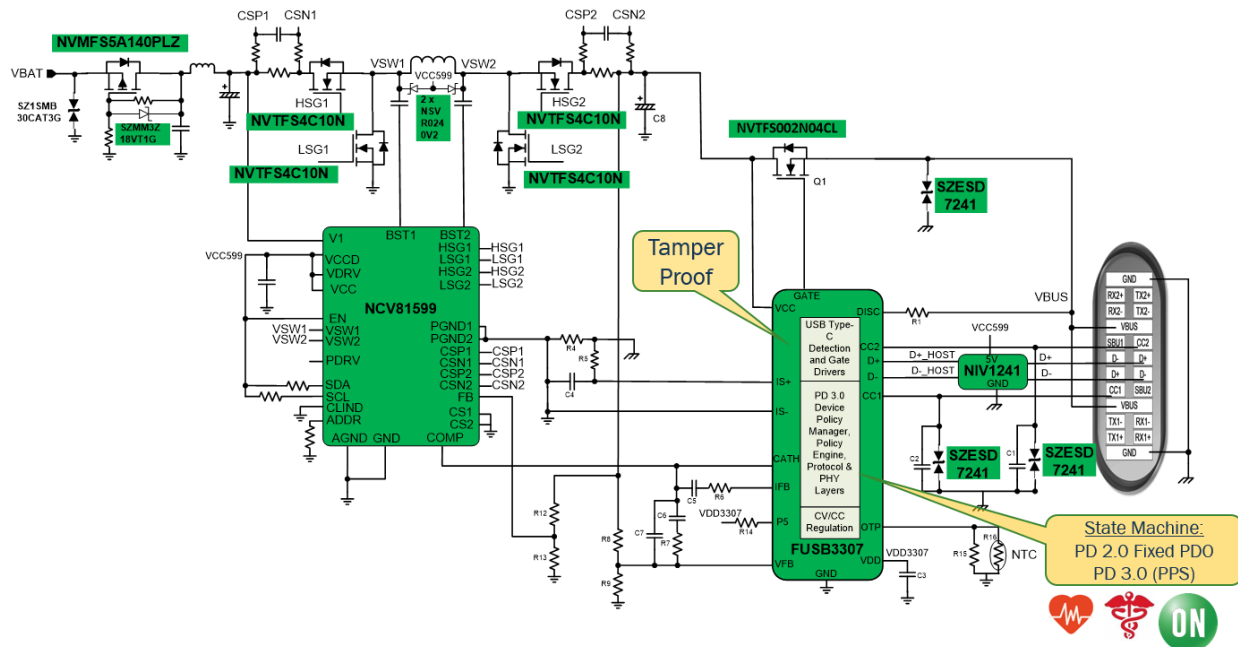

Figure 9

Check out the [FUSB3307 EVB](#) to learn more details. Continue learning about our [USB-C solutions](#) and how they can fulfill your design and solution needs in various applications.

Don't forget to subscribe to our blog to stay up-to-date on our latest technology releases and company initiatives!

[Twitter](#) | [Facebook](#) | [LinkedIn](#) | [Instagram](#) | [YouTube](#)