



# ASME Fox 3

## User Guide

Ver 1.3

Copyright 2016  
Axel Elettronica

[www.axeelettronica.it](http://www.axeelettronica.it)

## Copyright Notice and Disclaimer

All rights reserved. No parts of this manual may be reproduced in any form without the express written permission of Axel Elettronica.

Axel Elettronica makes no representations or warranties with respect to the contents hereof. In addition, information contained herein is subject to change without notice. Every precaution has been taken in the preparation of this manual. Nevertheless, Axel Elettronica assumes no responsibility for errors or omissions or any damages resulting from the use of the information contained in this publication.

Axel Elettronica does not assume any liability arising out of the application or use of any of its products or designs. Products designed or distributed by Axel Elettronica are not intended for, or authorized to be used in, applications such as life support systems or for any other use in which the failure of the product could potentially result in personal injury, death or property damage.

## Revision Sheet

Release No.	Date	Revision Description
Ver 1.0	14/12/2016	First Release
Ver 1.1	14/01/2017	PDF error conversion fixed & General review
Ver 1.2	31/01/2017	Fig. 2 and Fig. 5 changed
Ver 1.3	11/2/12017	MCU port column added to table 4; Tables 5,6,7 added

*Table 1: Document History*

# TABLE OF CONTENTS

Chapter 1	Introduction.....	5
1.1	Board Specifications .....	5
Chapter 2	Hardware.....	6
2.1	External View.....	6
2.2	ASME Fox 3 Block Diagram.....	6
2.3	ATMEL SAMD21 Ultra low-power ARM® Cortex®-M0+ MCU .....	7
2.4	Power Supply Circuitry.....	7
2.5	Sigfox Module (Telit LE51-868 S) .....	8
2.6	Crypto Authentication Chip (ATMEL ATECC508A).....	9
2.7	GPS Module with Embedded Antenna (Telit Jupiter SE868-A).....	10
2.8	Bluetooth Low Energy (Microchip RN4871) .....	10
2.9	32Kx8 Bits EEPROM (AT24C256C).....	11
2.10	Board Interfaces and Connector.....	12
Chapter 3	Mechanical Information.....	14
3.1	Main components layout.....	14
3.2	Mechanical Characteristics .....	14
Chapter 4	Software Development.....	15
Chapter 5	Getting Started with Arduino IDE and Sketch Projects .....	16
5.1	Tools.....	16
5.2	Setup the Environment.....	16
5.3	Compile the Example project.....	18
5.4	Run the software .....	18
5.5	Importing the SIGFOX SmartEverything Board Library .....	19
5.6	Official GitHub library repository .....	21
Chapter 6	References and Useful Links .....	22
6.1	Data sheets .....	22
6.2	Tools.....	22
6.3	Web Sites.....	22
Chapter 7	Troubleshooting .....	23
7.1	Driver installation problems.....	23

## Tables Index

Table 1: Document History .....	2
Table 2: Board Specifications .....	5
Table 3: Power Supply Connectors and ranges .....	8
Table 4: Arduino Compatible Headers.....	12
Table 5 BLE port description.....	13
Table 6 SIGFOX port description .....	13
Table 7 GPS/GNSS port description .....	13

## Illustrations Index

Figure 1: Front View.....	6
Figure 2: SmartEverything Block Diagram .....	6
Figure 3: Power Supply block diagram .....	8
Figure 4: Headers pinout.....	12
Figure 5: Main Component layout (top) .....	14
Figure 6: Dimensions .....	14
Figure 7: Launch Board Manager .....	16
Figure 8 ArduinoZero Core Installation .....	17
Figure 9: SmartEverything Core Installation .....	17
Figure 10: ArduinoIDE: Verify the code .....	19
Figure 11: ArduinoIDE: Upload the code.....	19
Figure 12: ArduinoIDE: Launch Manage Libraries interface .....	20
Figure 13: ArduinoIDE: Library Manager .....	20
Figure 14 Correct USB Driver installation .....	23

## Chapter 1 Introduction

This document describes **ASME Fox 3** SoM (System On Module) based on Atmel D21 Ultra low-power microcontroller using the 32-bit ARM® Cortex®-M0+ processor.

The **ASME Fox 3** Board provides the following peripherals or modules:

- Crypto Authentication chipset
- SIGFOX Module
- GPS Module with Embedded Antenna
- Bluetooth Low Energy (BLE) Interface

The **ASME Fox 3** Board is supported by the [Arduino IDE](https://www.arduino.cc/en/Main/Software) for a fast and easy software development cycle (<https://www.arduino.cc/en/Main/Software>).

The software can also be developed using the Atmel Studio IDE commonly preferred by professional software engineers (<http://www.atmel.com/Microsite/atmel-studio/>).

### 1.1 Board Specifications

Characteristics	Value
CPU Clock speed	48MHz
Flash Memory	256K
SRAM	32K
Connector	1 Power Jack 1 USB 1 SIGFOX antenna 1 Li-Po Battery 1 SWD Debugger Arduino compatible PinOut
Board supply voltage	6V – 24V CC
Operative Voltage	3.3V
Temperature	-40°C to +85°C
Dimensions	68x30 mm
RoHS status	Compliant

*Table 2: Board Specifications*

## Chapter 2 Hardware

### 2.1 External View

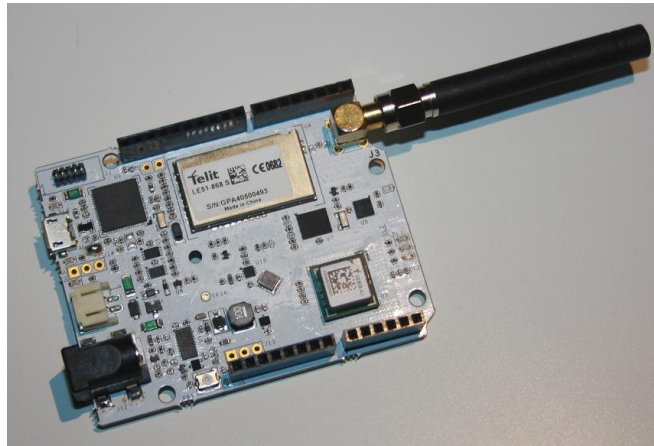

Figure 1: Front View

### 2.2 ASME Fox 3 Block Diagram

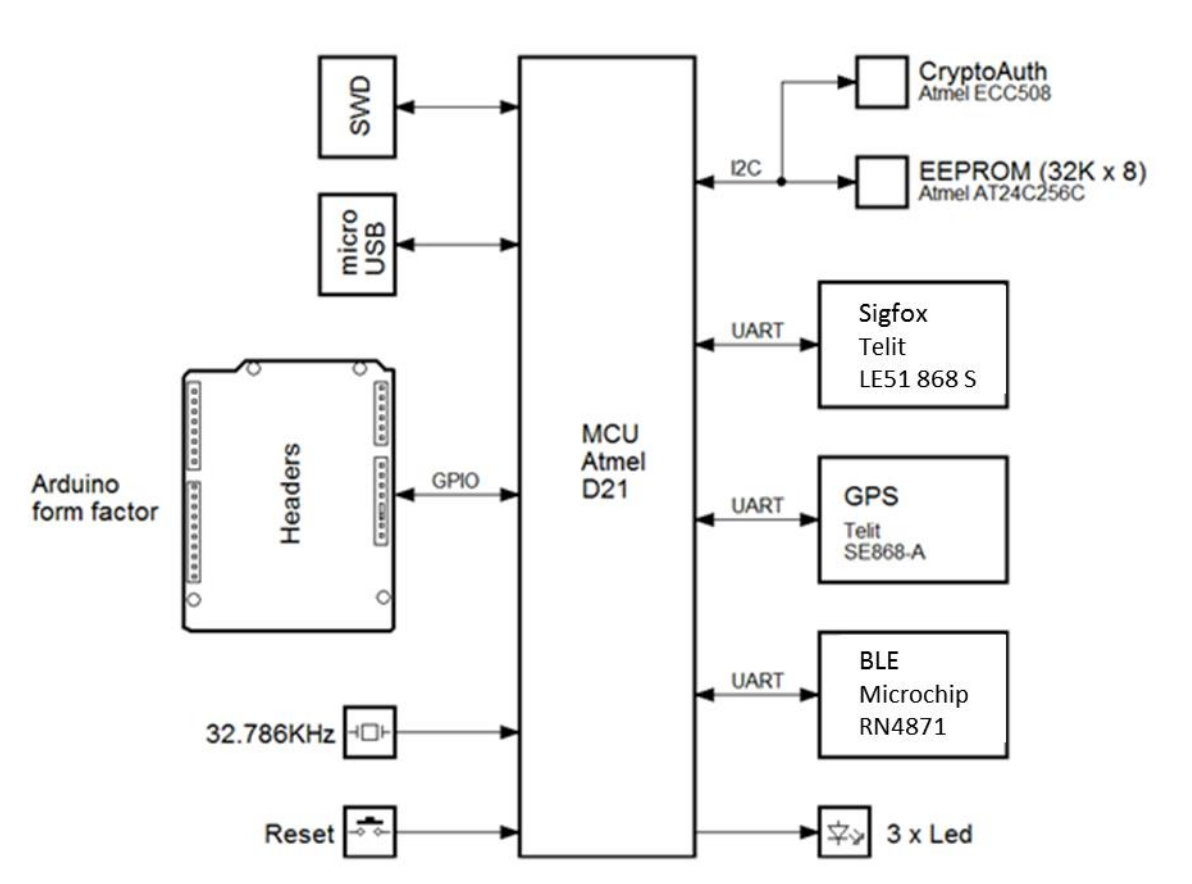

Figure 2: SmartEverything Block Diagram

## 2.3 ATMEL SAMD21 Ultra low-power ARM® Cortex®-M0+ MCU

Atmel D21 Ultra low-power microcontroller using the 32-bit ARM® Cortex®-M0+ processor is the core of the entire board.

### Memory

- 256KB in-system self-programmable Flash
- 8KB Flash Read-While-Write section
- 32KB SRAM Main Memory
- 8KB SRAM Low power Memory

### Clock Frequency

- 32.768kHz crystal oscillator (XOSC32K)

### Arduino compliance

- Digital i/o Pins : 20
- PWM Pins: all but 2 and 7
- USART: 2 (USB and TTL Digital)
- Analog Input Pins: 6, 12-bit DAC
- Analog Output Pins: 1, 10-bit DAC
- External Interrupts: All pins except pin 4

More information can be found on the ATMEL SAMD21 Data Sheet (See the link in Chapter 6 )

## 2.4 Power Supply Circuitry

The board can be powered by three different power supply sources:

- External Li-Po Battery
- A 6V to 24V input
- A 5V Mini USB connector

### WARNING:

**Li-Po batteries are charged at 4,2V with a current that is usually half of the nominal capacity (C/2). This board has a specialized chip that has a preset charging current of 350mAh. This means that the MINIMUM capacity of the Li-Po battery shall be 700 mAh. Smaller cells will be damaged by this current and may overheat, develop internal gasses and explode, setting the surroundings on fire.**

All of the components can work with the voltage range provided by the batteries, with the exception of the GPS module that requires at least 2.8V. For this reason, it is recommended to use an appropriate battery pack for a long use of the GPS.

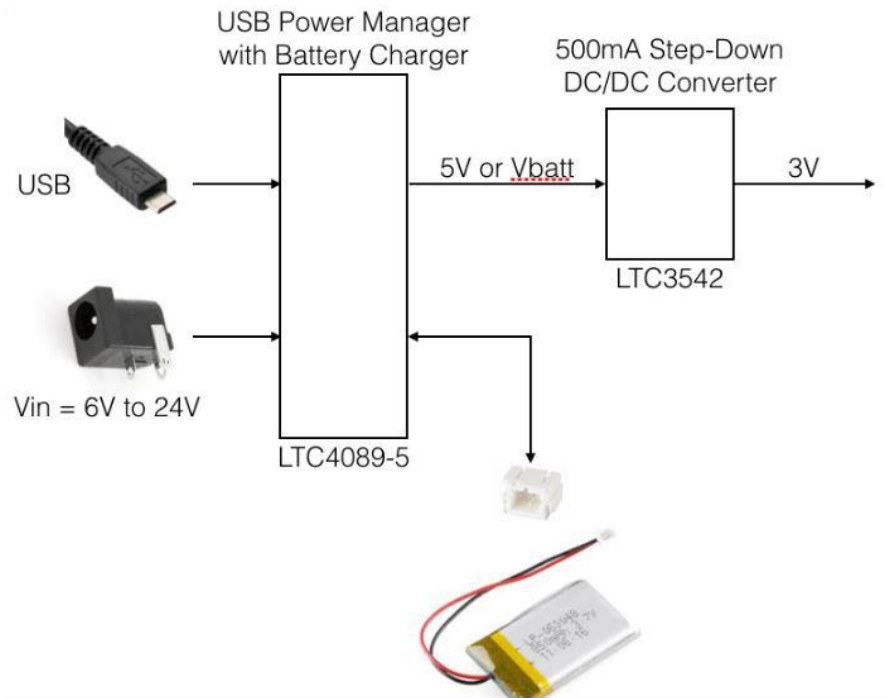

Figure 3: Power Supply block diagram

Name	Nominal	Description	Range
J10	3 V	Battery Power Supply	1.4V to 3.2V
J12	6V to 24V	External Power Supply	6V to 24V
USB	5V	USB Port	5V

Table 3: Power Supply Connectors and ranges

## 2.5 Sigfox Module (Telit LE51-868 S)

Telit LE51-868 S module is a high performance module designed to cover the 863-870MHz unlicensed band. It provides the Telit proprietary Star Network protocol and it is able to act as a certified Sigfox™ gateway.

The following protocol stack is preloaded:

- LE51-868 S SIGFOX™ Network Software.
- “Star Network” Protocol stack

### 2.5.1 Main Features

The LE51-868 S module is a complete solution from serial interface to RF interface.

The LE51-868 module has a digital part and a RF part. The radio link on the Sigfox network is a Half-Duplex bidirectional link.

The digital part has the following functionalities:

- Communication interface
- I/O management



- Micro controller with embedded Telit Software Stack supporting Sigfox protocol

The RF part has the following functionalities:

- Frequency synthesis
- Front-end
- Power amplification
- Packet handling

More information can be found on relevant Data Sheet (See the link in Chapter 6 )

## **2.6 *Crypto Authentication Chip (ATMEL ATECC508A)***

The ATECC508A is a member of the Atmel Crypto Authentication™ family of high-security hardware authentication devices. It has a flexible command set that allows its usage in many applications, including the following, among others:

- Anti-counterfeiting
- Protecting Firmware or Media
- Exchanging Session Keys
- Storing Data Securely
- Checking User Passwords

### **2.6.1 Device Features**

The ATECC508A device includes an Electrically Erasable Programmable Read-Only Memory (EEPROM) array that can be used for key storage, miscellaneous read/write data, read-only, secret data, consumption logging, and security configuration.

Access to the various sections of memory can be restricted in a variety of ways, and the configuration can then be locked to prevent changes.

The ATECC508A features a wide array of defense mechanisms specifically designed to prevent physical attacks against the device itself or logical attacks against the data transmitted between the device and the system

Hardware restrictions on the way keys are used or generated provide further defense against certain styles of attack.

Access to the device is made through a standard I2C interface.

Each ATECC508A ships with a guaranteed unique 9-byte (72-bit) serial number. Using the cryptographic protocols supported by the device, a Host system or remote server can prove that the serial number is authentic and is not a copy. Serial numbers are often stored in a standard Serial EEPROM, which can be easily copied with no way for the Host to know if the serial number is authentic or if it is a clone. The entire serial number must be utilized to guarantee uniqueness.

### **2.6.2 Cryptographic Operation**

The ATSHA204A supports a standard challenge-response protocol to simplify programming. In its most basic installation, the Host system sends a challenge (i.e. a number) to the device in the Client, which combines that challenge with a secret key by using the Message Authentication Code (MAC) command from the system and sends that response back to the system.

This basic operation can be expanded in many ways thanks to the flexible command set of

the ATECC508A.

For a complete explanation about the possible Cryptographic Operations check the Data Sheet (See the link in Chapter 6 )

## **2.7 GPS Module with Embedded Antenna (Telit Jupiter SE868-A)**

The Telit Jupiter SE868-A is a GPS Module designed to fully support GPS, QZSS, GLONASS and it is Galileo ready. It has an embedded SMT antenna and is able to track GPS + GLONASS (and eventually Galileo) constellations simultaneously and to provide the position through the standard serial interface (UART)

The module software can increase the position accuracy supporting:

- Ephemeris file injection (A-GPS)
- Satellite Based Augmentation System (SBAS)

More information can be found on relevant Data Sheet (See the link in Chapter 6 )

## **2.8 Bluetooth Low Energy (Microchip RN4871)**

The RN4871 is a small form factor, Bluetooth 4.2 Low-Energy module measuring just 9 x 11.5 x 2.1 mm. This fully-integrated module is designed for easy implementation into a broad range of applications. Supporting the latest Bluetooth standard, it delivers up to 2.5x throughput improvement and more secure connections vs. Bluetooth 4.1 based products.

Developers can easily interface to the device via a standard UART interface, available on most Microcontrollers and Processors.

### **2.8.1 Characteristics**

- FCC Certified        Yes
- Min Temp Range    -20C
- Max Temp Range    +70C
- Op Voltage Min     1.9V
- Op Voltage Max     3.6V

More information can be found on relevant Data Sheet (See the link in Chapter 6 )

The module on the board is provided with the firmware able to communicate with the ATMEL SAMD21 MCU

A suggested App for Android is [B-BLE](#)

(<https://play.google.com/store/apps/details?id=com.billy.billylightblue&hl=it>)

## **2.9 32Kx8 Bits EEPROM (AT24C256C)**

The Atmel® AT24C256C provides 262,144-bits of Serial Electrically Erasable and Programmable Read-Only Memory (EEPROM) organized as 32,768 words of 8 bits each.

The device's cascading feature allows up to eight devices to share a common 2-wire bus. The device is optimized for use in many industrial and commercial applications where low-power and low-voltage operation are essential.

The device operates from 1.7V to 5.5V.

More information can be found on relevant Data Sheet (See the link in Chapter 6 )

### **2.9.1 Characteristics**

- Low-voltage and Standard-voltage Operation–VCC = 1.7V to 5.5V
- 400kHz (1.7V) and 1MHz (2.5V, 2.7V, 5.0V) Compatibility
- Write Protect Pin for Hardware Protection
- 64-byte Page Write Mode–Partial Page Writes Allowed
- High Reliability–Endurance: 1,000,000 Write Cycles–Data Retention: 40 Years

### **2.9.2 EEPROM Address**

The EEPROM is mapped to the following I2C address 0x57

## 2.10 Board Interfaces and Connector

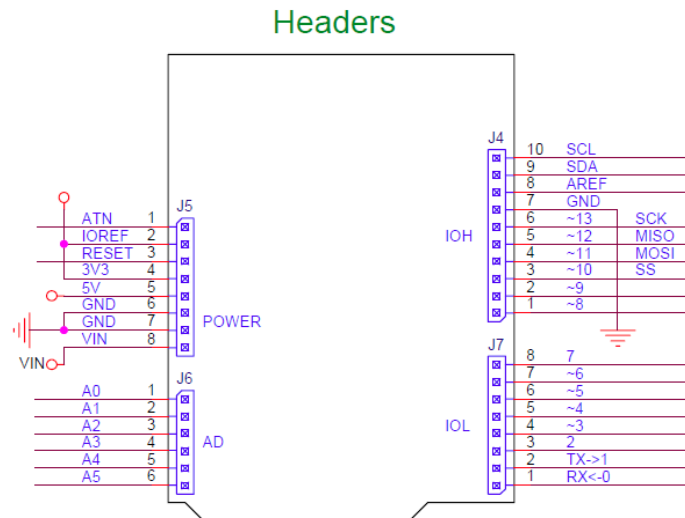

Figure 4: Headers pinout

Conn.	Pin	Description	Arduino pin label	Driven by
J4	1	Digital I/O D8 / PWM	~8	MCU Port PA06
J4	2	Digital I/O D9 / PWM	~9	MCU Port PA07
J4	3	Digital I/O D10 / PWM SS	~10	MCU Port PA18
J4	4	Digital I/O D11 / PWM MOSI	~11	MCU Port PA16
J4	5	Digital I/O D12 / PWM MISO	~12	MCU Port PA19
J4	6	Digital I/O D13 / PWM SCK	~13	MCU Port PA17
J4	7	Ground pin	GND	
J4	8	Analogue Reference (used by ADC)	AREF	MCU Port PA03
J4	9	I2C Interface SDA	SDA	MCU Port PA22
J4	10	I2C Interface SCL	SCL	MCU Port PA23
J5	1	Digital I/O ATN	ATN	MCU Port PB06
J5	2		IOREF	
J5	3	Reset	RESET	
J5	4		3.3V	
J5	5		5V	
J5	6	Ground pin	GND	
J5	7	Ground pin	GND	
J5	8	External Power Supply Input	VIN	
J6	1	Analog I/O A0	A0	MCU Port PA02
J6	2	Analog I/O A1	A1	MCU Port PB08
J6	3	Analog I/O A2	A2	MCU Port PB09
J6	4	Analog I/O A3	A3	MCU Port PA04
J6	5	Analog I/O A4	A4	MCU Port PA05
J6	6	Analog I/O A5	A5	MCU Port PB02
J7	1	Digital I/O D0 / Serial1 (RX)	RX<-0	MCU Port PA11
J7	2	Digital I/O D1 / Serial1 (TX)	TX->1	MCU Port PA10
J7	3	Digital I/O D2 / PWM	~2	MCU Port PA14
J7	4	Digital I/O D3 / PWM	~3	MCU Port PA09
J7	5	Digital I/O D4 / PWM	~4	MCU Port PA08
J7	6	Digital I/O D5 / PWM	~5	MCU Port PA15
J7	7	Digital I/O D6 / PWM	~6	MCU Port PA20
J7	8	Digital I/O D7 / PWM	~7	MCU Port PA21

Table 4: Arduino Compatible Headers

Description	Driven by
BLE TXD	MCU Port PB16
BLE RXD	MCU Port PB17
BLE RTS	MCU Port PB22
BLE CTS	MCU Port PB23
BLE P10	I/O Expander GPIO4
BLE P11	I/O Expander GPIO5
BLE P32	I/O Expander GPIO6
BLE P33	I/O Expander GPIO7
BLE RST	I/O Expander GPIO1

*Table 5 BLE port description*

Description	Driven by
SFX TXD	MCU Port PB12
SFX RXD	MCU Port PB13
SFX RTS	MCU Port PB14
SFX CTS	MCU Port PB15
SFX RADIO STS	MCU Port PB07
SFX STDBY STS	MCU Port PB10
SFX WAKE UP	MCU Port PB11
SFX RST	I/O Expander GPIO0

*Table 6 SIGFOX port description*

Description	Driven by
GPS TXD	MCU Port PA12
GPS RXD	MCU Port PA13
GPS RST	I/O Expander GPIO2
GPS FORCE ON	I/O Expander GPIO3

*Table 7 GPS/GNSS port description*

## Chapter 3 Mechanical Information

### 3.1 Main components layout

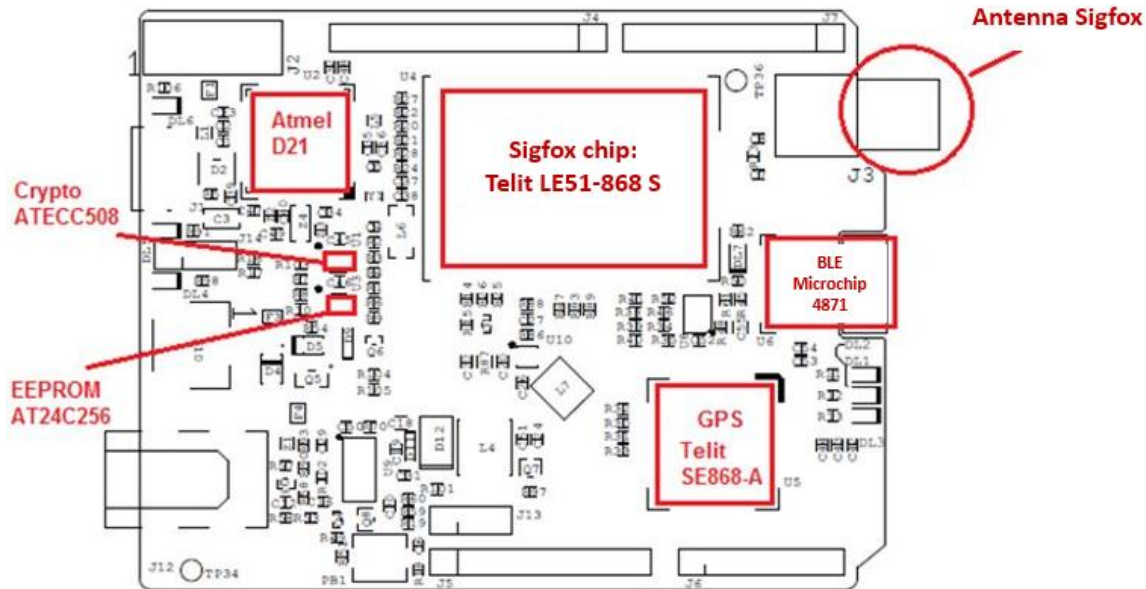

Figure 5: Main Component layout (top)

### 3.2 Mechanical Characteristics

The maximum length and width of the Smarteverything Fox 3 PCB are 2.7 and 2.1 inches respectively, with the USB connectors, power jack and antenna extending beyond the former dimension. Three screw holes allow the board to be attached to a surface or a case. Note that the distance between digital pins 7 and 8 is 160 mil (0.16"), not an even multiple of the 100 mil spacing of the other pins.

This makes the SmartEverything Fox 3 fully compatible with most shields designed for the Uno, Diecimila or Duemilanove.

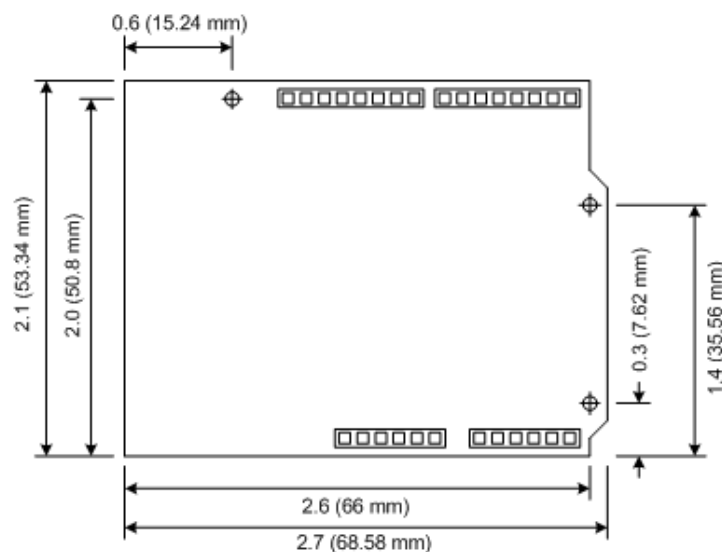

Figure 6: Dimensions

## Chapter 4 Software Development

The following chapters provide an overview about how a user can develop its software and run it on the ASME Fox 3 board.

There are two main ways to develop a software, load it and debug it on the card:

- Using the Arduino IDE and Sketch Projects
- Using the Atmel Studio and Standard C/C++ language

When developing a software running on a microcontroller, it is important to have some tools to easily debug the code and to fix what does not work as expected.

It is possible to use an external debugger like the [Atmel-ICE](#) .

(<http://www.atmel.com/tools/atatmel-ice.aspx>) is available.

## Chapter 5 Getting Started with Arduino IDE and Sketch Projects

### 5.1 Tools

The following tools are needed:

- Arduino IDE (Release 1.6.4 or newer)
- USB cable

### 5.2 Setup the Environment

Download and install the Arduino IDE from the Arduino web site (See the link in Chapter 6 )

The first time you run the ArduinoIDE, it is necessary to load the Arduino Zero & SmartEverything Core.

Click on the Tools -> Boards ->Boards Manager... menu entry

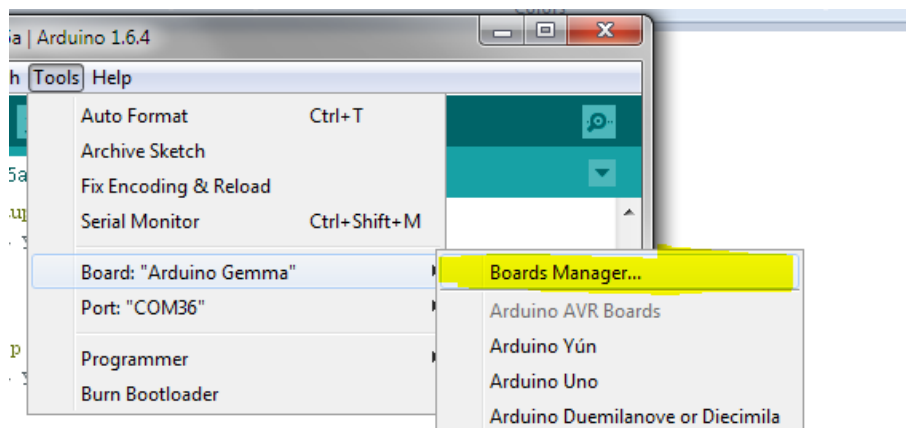

Figure 7: Launch Board Manager



The two installation steps shall be done as follows:

- 1) Select from “Type” combo **Arduino** and choose **Arduino SAMD Boards** in order to install the core of the Arduino Zero.

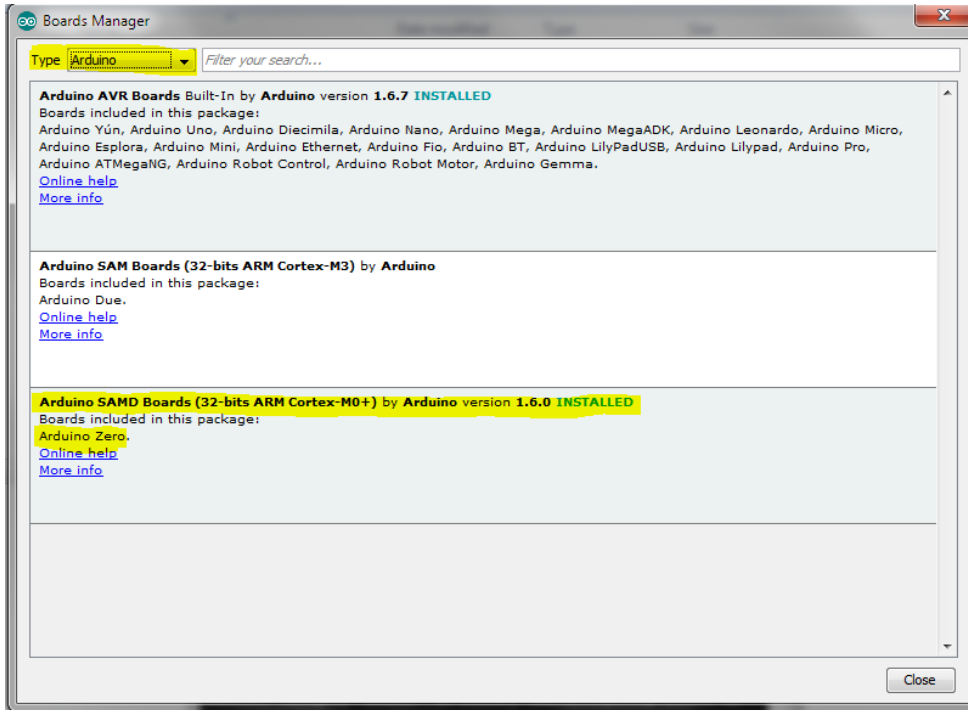

Figure 8 ArduinoZero Core Installation

- 2) Select from “Type” combo **Partner** and choose the **ARROW Boards** in order to install the core of the SmartEverything.

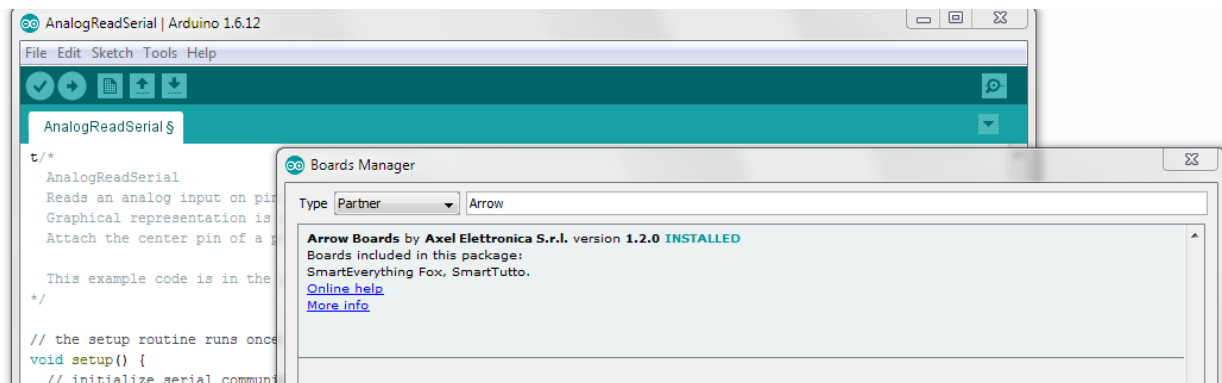

Figure 9: SmartEverything Core Installation

The installation procedure will automatically install all the necessary USB drivers. Once the installation is completed, you can connect the Board and start coding.

If the Driver installation process does not complete successfully, follow the steps described in Chapter 7 .

### 5.3 Compile the Example project

This procedure explains how to compile and download the code on the SmartEverything Fox 3 board.

As any other Arduino boards, the SmartEverything Fox 3 has the basic examples code.

To try those examples, go to File->Examples and select one under the 01.Basics menu.

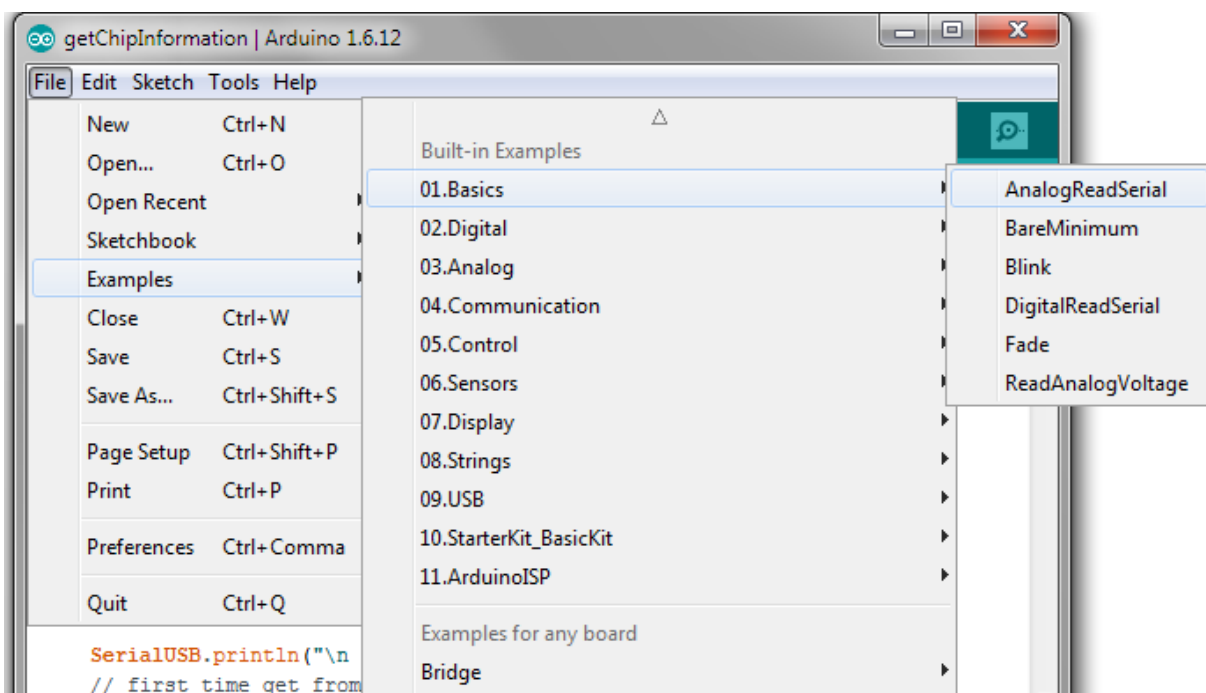

### 5.4 Run the software

Verify the code

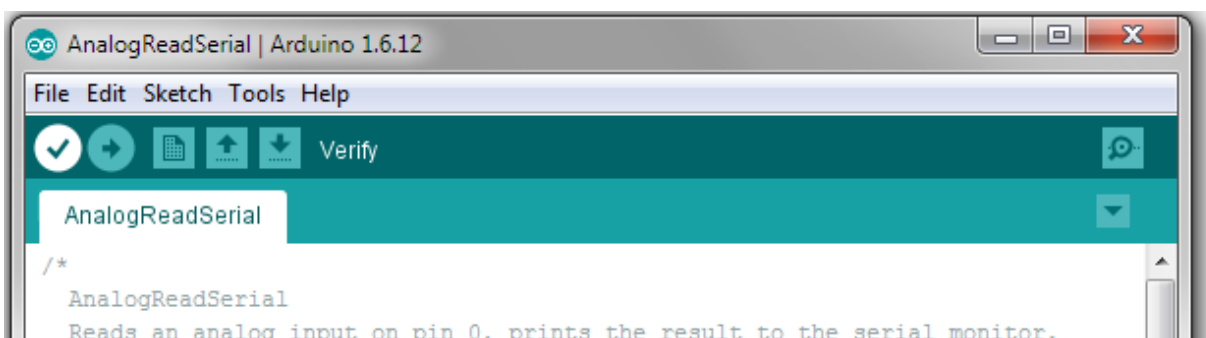

Figure 10: ArduinoIDE: Verify the code

Load the software on the Connect the SmartEverything Fox 3 board.

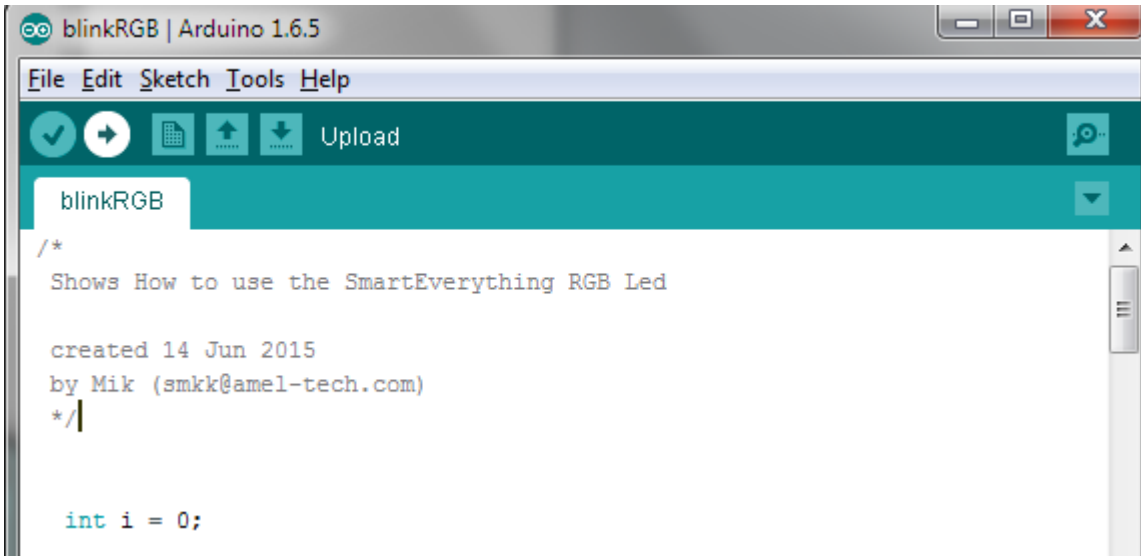

Figure 11: ArduinoIDE: Upload the code

### 5.5 Importing the SIGFOX SmartEverything Board Library

The SmartEverything Fox 3 board will provide, some days after its release on the market, some useful libraries to interface with some of its main components.

In order to include the Smart Everything library use the menu Sketch → Include Library → Manage Libraries.

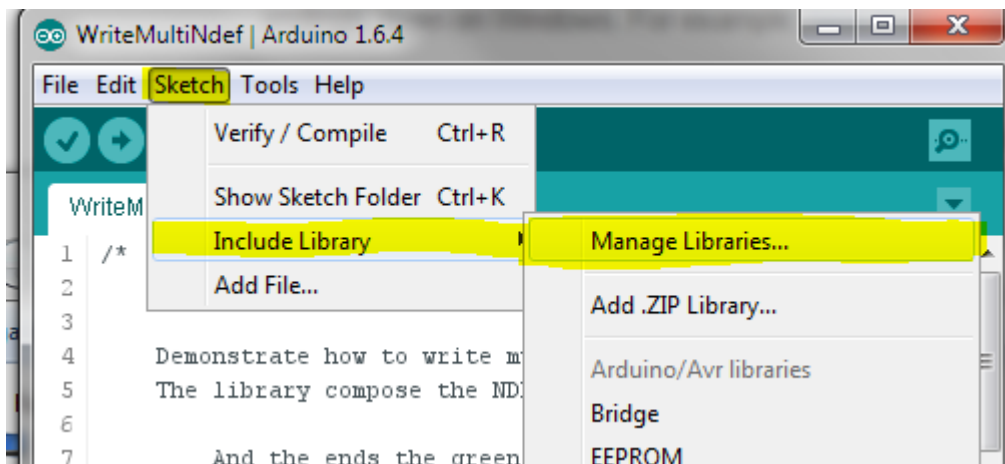

Figure 12: ArduinoIDE: Launch Manage Libraries interface

Once the Library Manager is started, you can filter the available libraries writing SmartEverything, or the name of the component, in the right top text box and then you can select the necessary library.

The procedure to download the other SmartEverything Fox 3 libraries is identical.

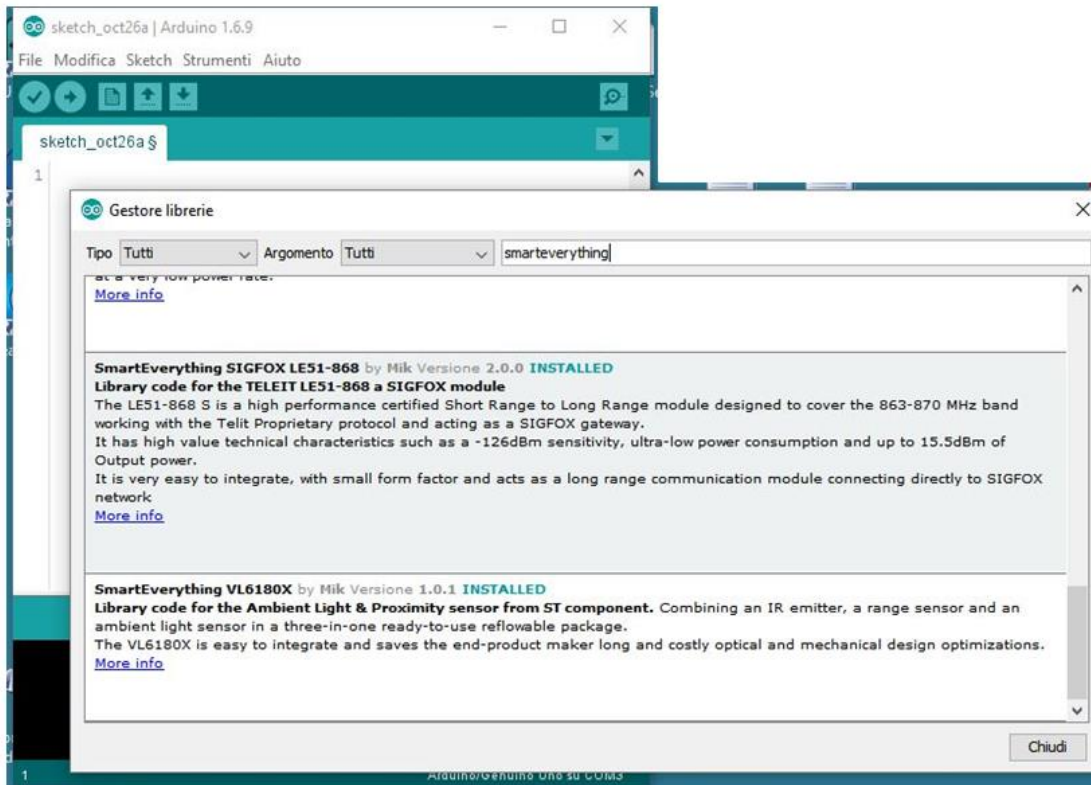
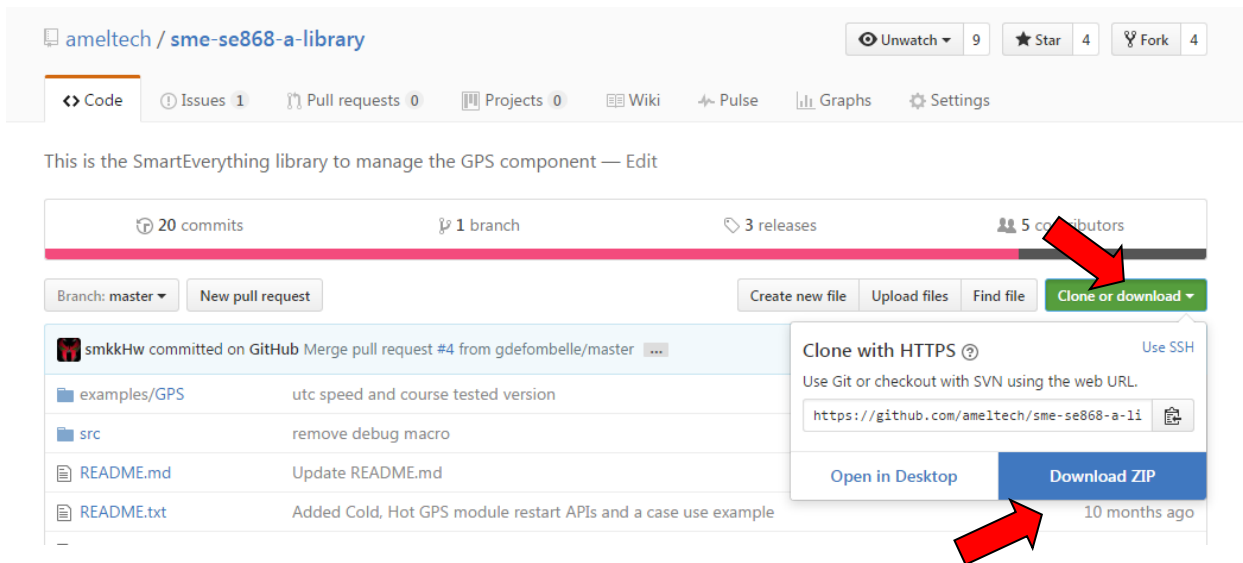

Figure 13: ArduinoIDE: Library Manager

Another way to install the supported components Library is to go to the GitHub repository and download the zip file.



Once it is downloaded, go to the “include Library” menu and use the “Add .ZIP Library...” item.

## 5.6 Official GitHub library repository

Here is the official repository where the zip file can be downloaded from:

- SIGFOX Library (<https://github.com/ameltech/sme-le51-868-library>)
- GPS Library (<https://github.com/ameltech/sme-se868-a-library>)
- BLE Library (<https://github.com/axelettronica/sme-rn4870-library>)
- EEPROM Library (<https://github.com/PaoloP74/extEEPROM>)

The EEPROM shall be initialized with these parameters  
`new extEEPROM(kbits_256, 1, 64, 0x57);`

## Chapter 6 References and Useful Links

### 6.1 Data sheets

- [ATMEL SAMD21 Ultra low-power ARM® Cortex®-M0+ MCU](http://www.atmel.com/Images/Atmel-42181-SAM-D21_Datasheet.pdf)  
[http://www.atmel.com/Images/Atmel-42181-SAM-D21\\_Datasheet.pdf](http://www.atmel.com/Images/Atmel-42181-SAM-D21_Datasheet.pdf)
- [Crypto Authentication Chip \(ATMEL ATECC508A\)](http://www.atmel.com/devices/atecc508a.aspx)  
<http://www.atmel.com/devices/atecc508a.aspx>
- Dynaflex 868Mhz Antenna (915/2)
- [Sigfox Module \(Telit LE51-868 S\)](http://www.telit.com/sr-rf/le51-868-s/)  
<http://www.telit.com/sr-rf/le51-868-s/>
- [GPS Module with Embedded Antenna \(Telit Jupiter SE868-A\)](http://www.telit.com/products/product-service-selector/product-service-selector/show/product/jupiter-se868-a/)  
<http://www.telit.com/products/product-service-selector/product-service-selector/show/product/jupiter-se868-a/>
- [BLE Microchip RN4871](http://www.microchip.com/wwwproducts/en/RN4871)  
<http://www.microchip.com/wwwproducts/en/RN4871>
- [E2Prom ATMEL \(AT24C256C\)](http://www.atmel.com/images/atmel-8568-seeprom-at24c256c-datasheet.pdf)  
<http://www.atmel.com/images/atmel-8568-seeprom-at24c256c-datasheet.pdf>

### 6.2 Tools

- Arduino [IDE](#)
- [Atmel Studio](#)

### 6.3 Web Sites

- Axel Elettronica – [www.axelelettronica.it](http://www.axelelettronica.it)
- Arduino – [www.arduino.cc](http://www.arduino.cc)
- Atmel – [www.atmel.com](http://www.atmel.com)
- Microhip - <http://www.microchip.com/>

## Chapter 7 Troubleshooting

### 7.1 Driver installation problems

It can happen that the installation of the driver does not automatically complete successfully. The driver to manage the COM Port are not installed properly and the device is reported as an Unknown Device.

If this happens, it is necessary to install the driver manually.

The correct drivers can be found on the following directory:

C:\Users\<login name> \AppData\Local\Arduino15\packages\Arrow\hardware\samd\<installed Rel>\drivers.

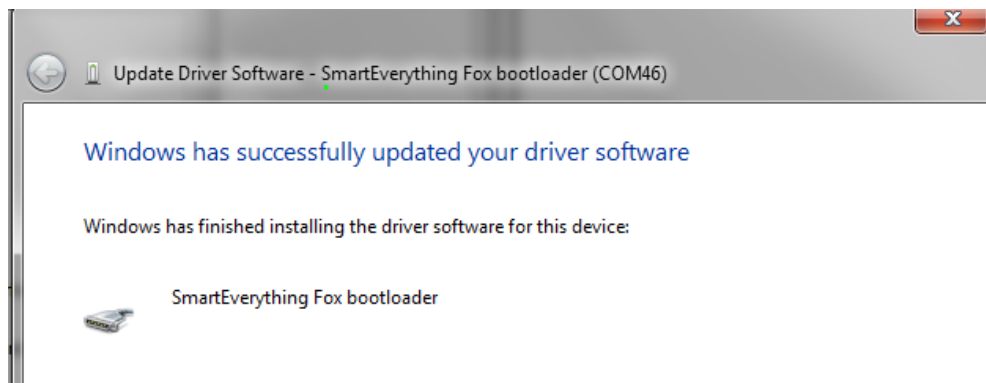

*Figure 14 Correct USB Driver installation*