

## Product Brief

# EiceDRIVER™ sense

## 1EDI2010AS

The 1EDI2010AS is a high-voltage IGBT gate driver designed for motor drives above 5 kW. The 1EDI2010AS is based on Infineon's Coreless Transformer (CLT) technology, providing galvanic insulation between low voltage and high voltage domains. The device has been designed to support IGBT technologies up to 1200 V.

The internal 8-bit ADC, with programmable gain and offset, enables the sensing of either the DC-link voltage, the phase voltage or of the temperature sensor located on the power module. The digitalized value can be read via the SPI interface. Moreover, the 1EDI2010AS supports advanced functions (such as two level turn-on and off, overcurrent monitoring, etc.), that can be controlled via the SPI interface.

The 1EDI2010AS can be used optimally with Infineon's integrated booster stage family EiceDRIVER™ boost 1EBN100XAE.

### Circuit diagram

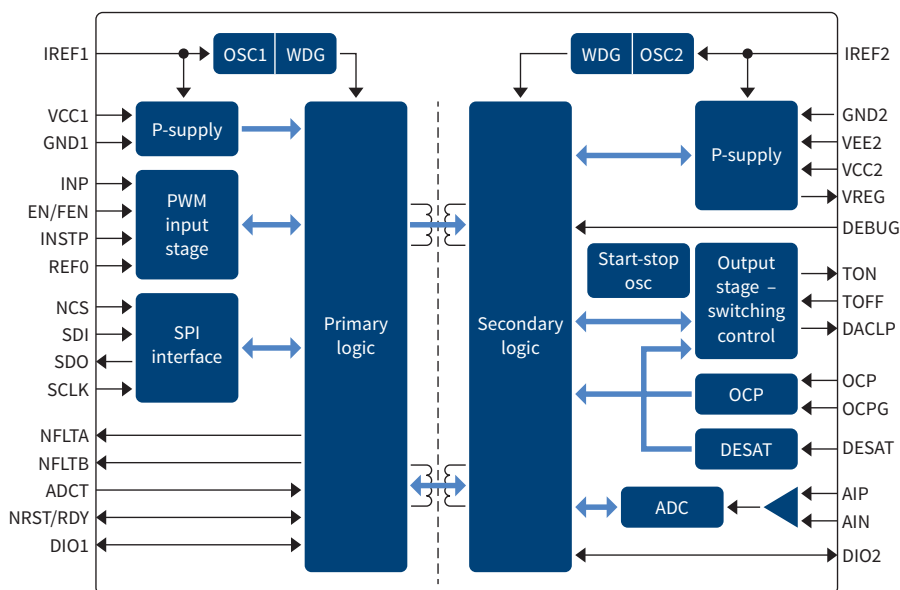

### Key features

- > On-chip galvanic isolation
- > Standard SPI interface
- > Embedded 8-bit ADC
- > Gate signal shaping
- > Overcurrent monitoring
- > AEC-Q100 qualified

### Key benefits

- > Embedded ADC reduces significantly system costs
- > The combined use with the EiceDRIVER™ boost saves significant PCB area
- > Two-level turn-on increases the system's efficiency

### Applications

- > Inverters for automotive Hybrid and Electric Vehicles (HEV)
- > High-voltage DC-DC converter
- > Industrial drive

# EiceDRIVER™ sense

1EDI2010AS

## Application block diagram

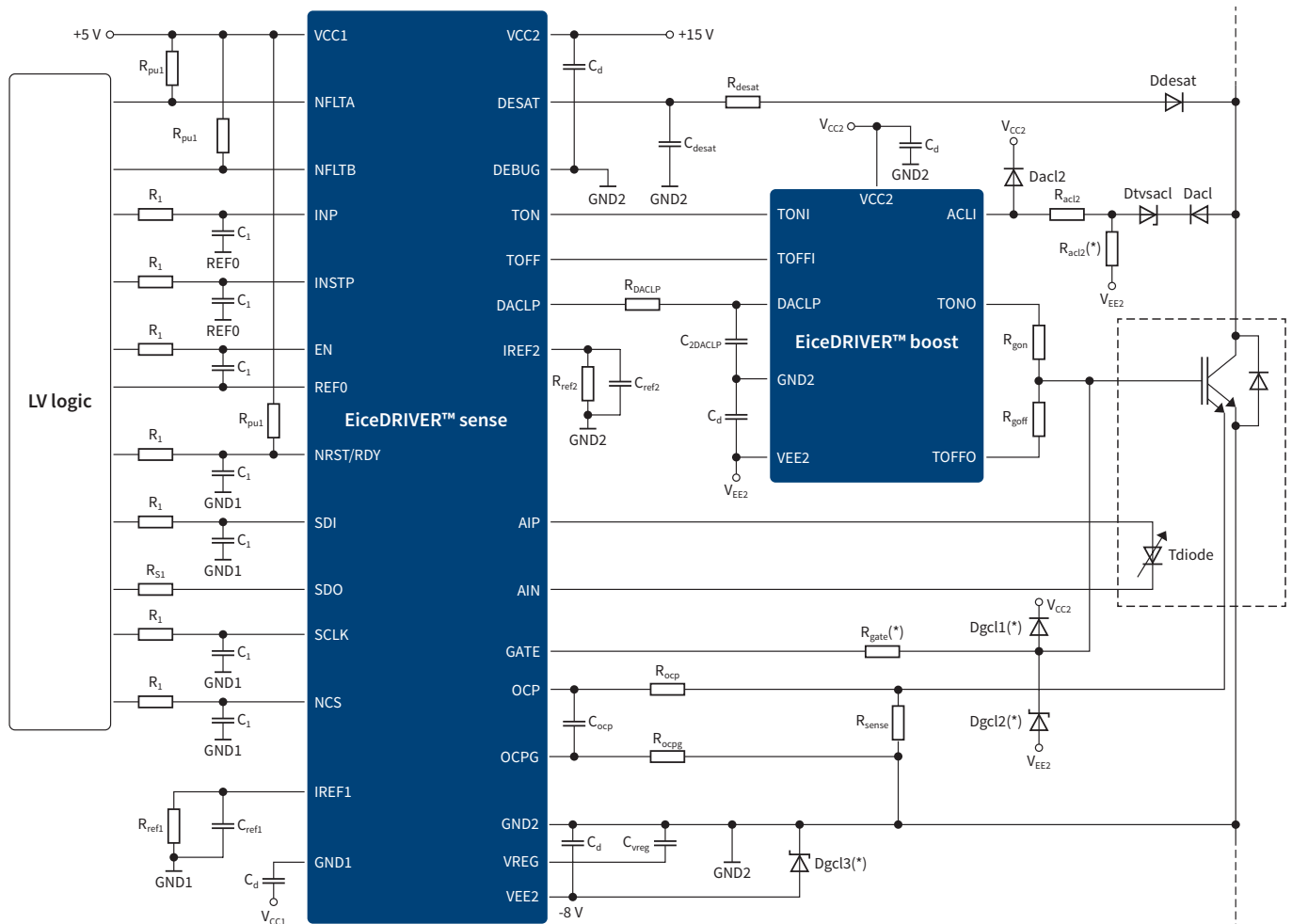

## Application example for a main inverter application

## Product summary

Type	Description	Ordering code
1EDI2010AS	EiceDRIVER™ sense	SP001299836

Published by  
Infineon Technologies AG  
81726 Munich, Germany

© 2017 Infineon Technologies AG.  
All Rights Reserved.

### Please note!

THIS DOCUMENT IS FOR INFORMATION PURPOSES ONLY AND ANY INFORMATION GIVEN HEREIN SHALL IN NO EVENT BE REGARDED AS A WARRANTY, GUARANTEE OR DESCRIPTION OF ANY FUNCTIONALITY, CONDITIONS AND/OR QUALITY OF OUR PRODUCTS OR ANY SUITABILITY FOR A PARTICULAR PURPOSE. WITH REGARD TO THE TECHNICAL SPECIFICATIONS OF OUR PRODUCTS, WE KINDLY ASK YOU TO REFER TO THE RELEVANT PRODUCT DATA SHEETS PROVIDED BY US. OUR CUSTOMERS AND THEIR TECHNICAL DEPARTMENTS ARE REQUIRED TO EVALUATE THE SUITABILITY OF OUR PRODUCTS FOR THE INTENDED APPLICATION.

WE RESERVE THE RIGHT TO CHANGE THIS DOCUMENT AND/OR THE INFORMATION GIVEN HEREIN AT ANY TIME.

### Additional information

For further information on technologies, our products, the application of our products, delivery terms and conditions and/or prices, please contact your nearest Infineon Technologies office ([www.infineon.com](http://www.infineon.com)).

### Warnings

Due to technical requirements, our products may contain dangerous substances. For information on the types in question, please contact your nearest Infineon Technologies office.

Except as otherwise explicitly approved by us in a written document signed by authorized representatives of Infineon Technologies, our products may not be used in any life-endangering applications, including but not limited to medical, nuclear, military, life-critical or any other applications where a failure of the product or any consequences of the use thereof can result in personal injury.